

TRI MO QBISS SCREEN

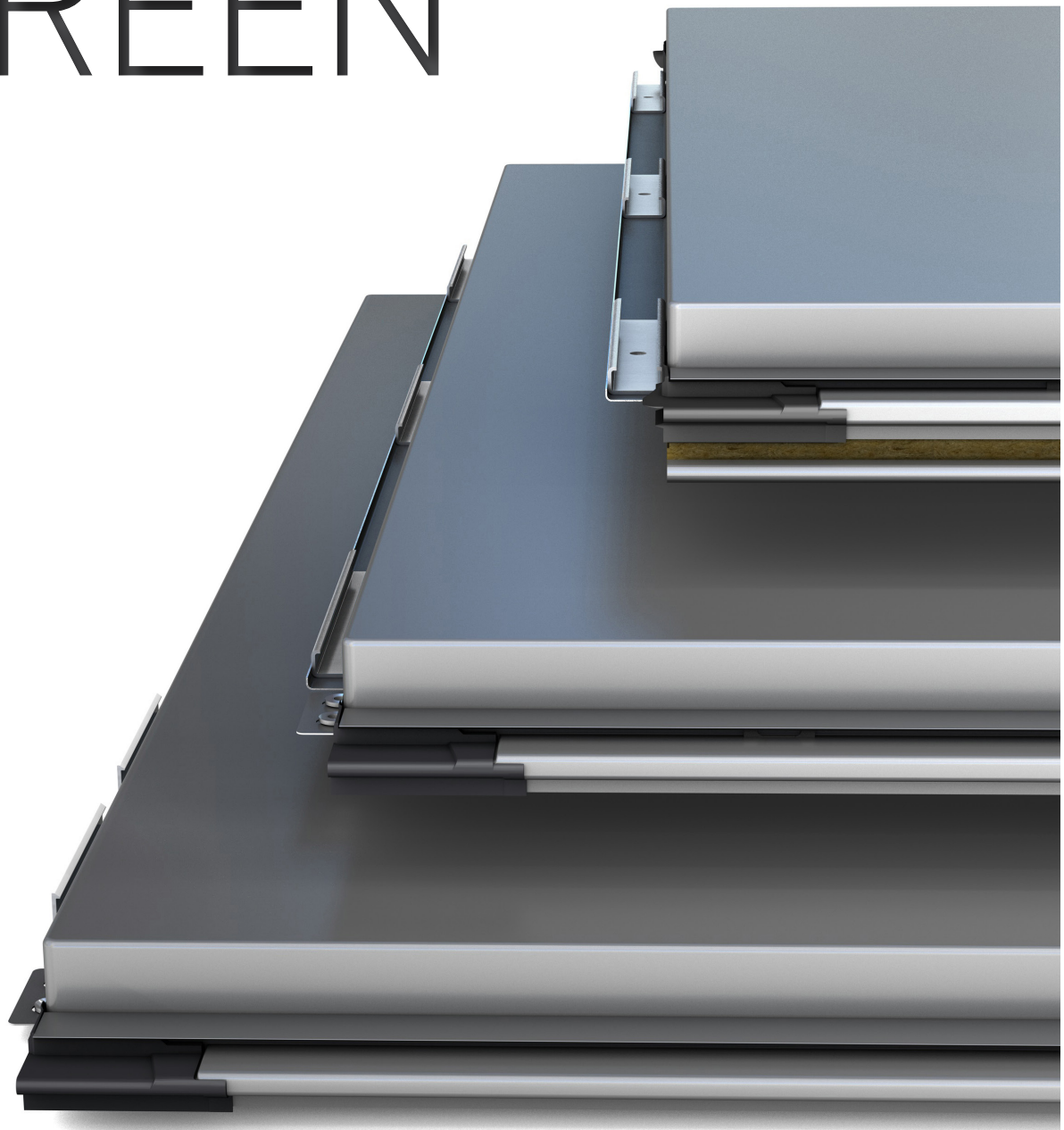

QBISS SCREEN INSTALLATION GUIDE

<p>A DISCOVER (PAGE A 04 - 05)</p> <ul style="list-style-type: none"> - Qbiss Screen, innovative metal rainscreen system 	<p>E INSTALLATION GUIDE (PAGE E 64 - 93)</p> <ul style="list-style-type: none"> - preparation for installation, handling and lifting of Qbiss Screen elements removing the protective foil - installation preferences, installation requirements - horizontal installation steps, installation step 1 installation step 2 installation step 3 installation step 4 installation step 5 - vertical installation steps, installation step 1 installation step 2 installation step 3 installation step 4 installation step 5 - system sealing sealing details overview - checklist
<p>B ELEMENT DESCRIPTION (PAGE B 06 - 21)</p> <ul style="list-style-type: none"> - element composition, composition steel skin thickness and profile colour your design corrosion protection core - measurements, measurements - technical data, technical data for Qbiss Screen façade elements 	<p>F SYSTEM RECOMMENDATIONS (PAGE F 94 - 99)</p> <ul style="list-style-type: none"> - damaged elements, replacement of damaged elements - cutting and sealing
<p>C ACCESSORIES (PAGE C 22 - 35)</p> <ul style="list-style-type: none"> - corner elements, uniqueness of Qbiss Screen elements 	<p>G SERVICE & SUPPORT (PAGE G 100 - 103)</p> <ul style="list-style-type: none"> - product management, managing the products product development - associated documents Qbiss Screen documents
<p>D SYSTEM DESCRIPTION (PAGE D 36 - 63)</p> <ul style="list-style-type: none"> - system composition, ventilated façade summer daytime performance complete building envelope system - installation methods, installation direction various installation methods - joint options, element variations - selection of fixing and methods selection of fixing according to design requirements Qbiss Screen element fixing 	

QBISS SCREEN

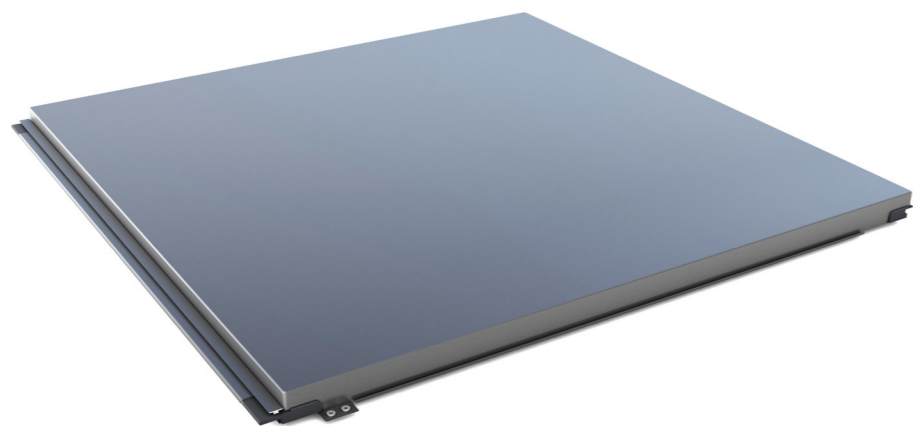

INNOVATIVE METAL RAINSCREEN

Qbiss Screen brings a system-approach to ventilated façades. Prefabricated elements produced in a controlled environment are delivered to the building site with consistent quality.

Suitable for both new-build and refurbishment projects, it comprises of an aluminium honeycomb or a mineral wool structural core, held between two metal skins. Qbiss Screen is equally applicable as exterior or interior wall, as well as interior ceiling and external soffit.

Versatile and flexible, Qbiss Screen can be combined with Qbiss One to further enhance the building envelope. Qbiss Screen has also been rigorously tested to the appropriate fire and wind resistance standards and meeting A2-s1, d0 fire classification.

ERLANGEN HALLENBAD
GERMANY

HORIZONTAL QBISS SCREEN MW

2017

FRITZ PLANUNG





B. ELEMENT DESCRIPTION

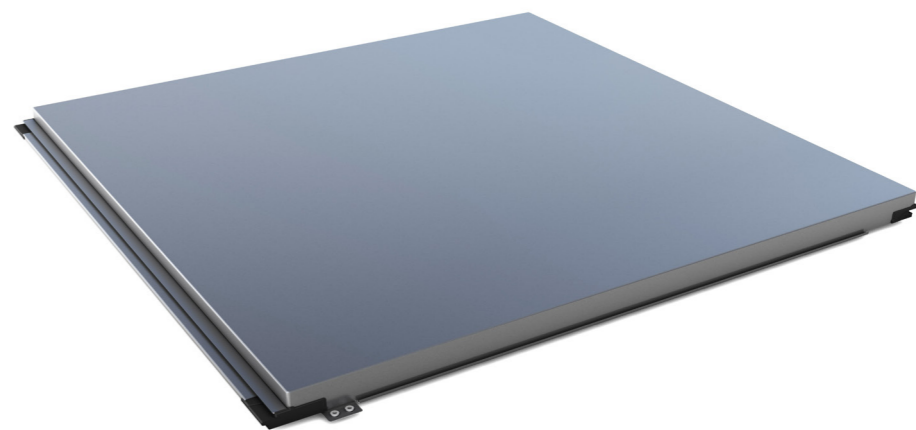

ELEMENT COMPOSITION

COMPOSITION

The basic Qbiss Screen element is a modular rainscreen element, made by an automated and robotized production line.

Qbiss Screen façade element is a composite element that consists of two pre-painted galvanized steel sheets with joints and a core. The purpose of the core is to strengthen the element and to achieve long spans. There are 2 different possibilities for core element: Mineral wool and Honeycomb. All layers combined form a solid 65 mm or 50 mm thick element. The element is suitable for horizontal and vertical installation.

Preinstalled gaskets prevent water to enter the system, while decorative Al extrusion defines colour of the joint.

QBISS SCREEN COMPOSITION TYPES

MW

Qbiss Screen MW is sophisticated modular rainscreen, providing superior protection against weather while keeping the building safe from corrosion atmospheric pollutants. Light, 65mm thick and easy to install rainscreen elements with mineral wool core, rounded corners, and unmatched flatness are prefabricated in controlled environment and delivered to construction site, cut to size.

H

The 50 mm thick element is a composite made of two pre-painted galvanized steel sheets with joints and honeycomb core. The composition of materials gives elements visibly higher level of surface flatness, high load-bearing capacity, minimal thermal expansion, thermal deflection and resistance to humidity.

H+

50 mm thick rainscreen comprises of an aluminium honeycomb core, inserted between two metal skins, with each element corner formed without cutting or folding. All joints are specially formed for fixing and sealing, with prefabricated lap joint on the side for self-weight fixing. Compared to Qbiss Screen H, the joint and the method of fixing has been redesigned.

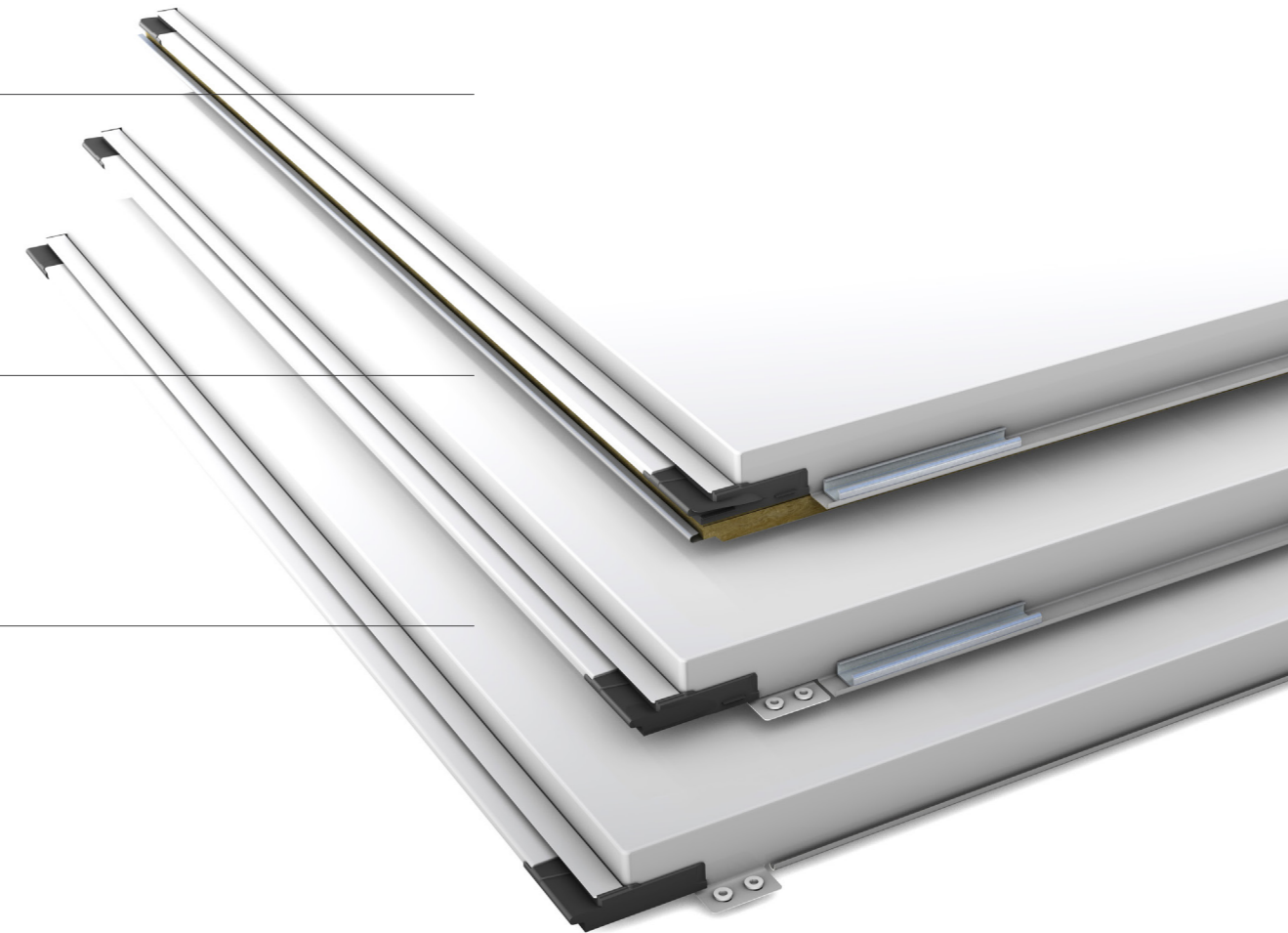

MW

Qbiss Screen MW

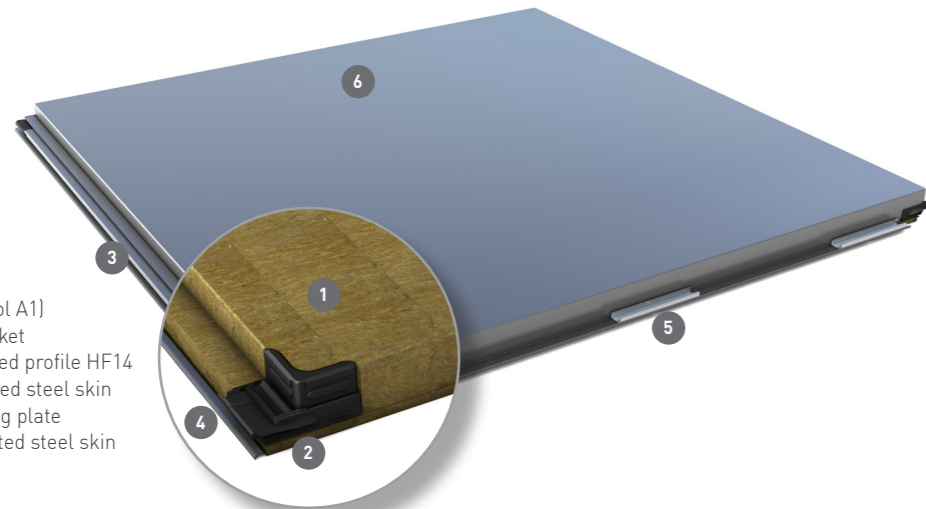

- 1 Core (mineral wool A1)
- 2 EPDM corner gasket
- 3 Decorative extruded profile HF14
- 4 Internal pre-painted steel skin
- 5 Load bearing fixing plate
- 6 External pre-painted steel skin

H

Qbiss Screen H

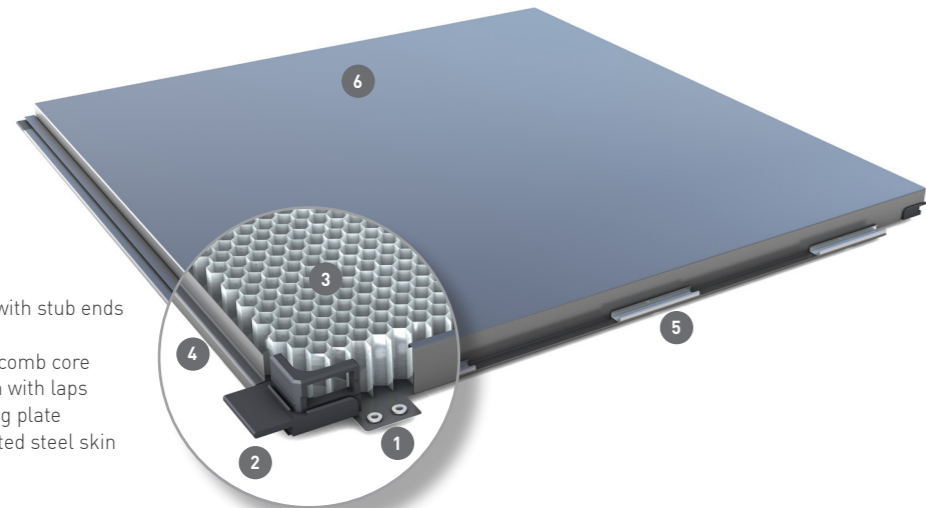

- 1 Lap joint flanges with stub ends
- 2 Al corner gasket
- 3 Aluminium honeycomb core
- 4 Internal steel skin with laps
- 5 Load bearing fixing plate
- 6 External pre-painted steel skin

H+

Qbiss Screen H+

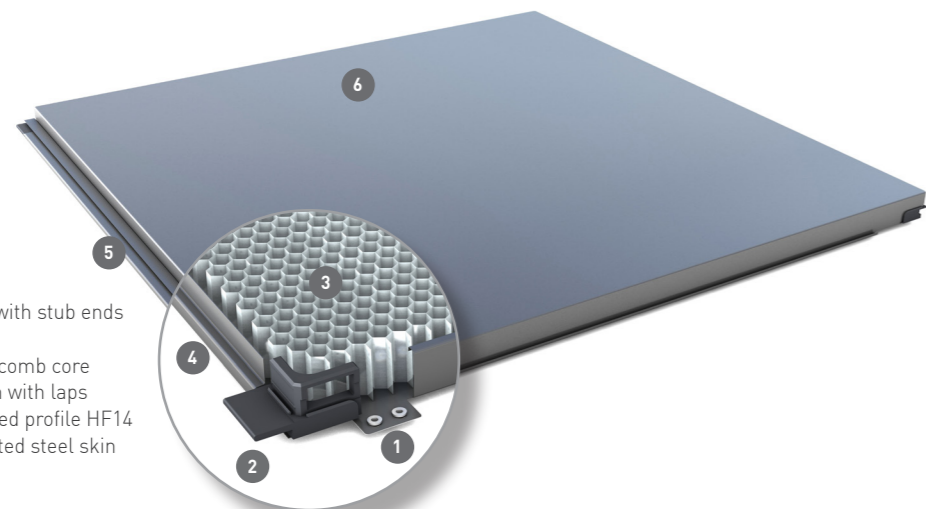

- 1 Lap joint flanges with stub ends
- 2 Al corner gasket
- 3 Aluminium honeycomb core
- 4 Internal steel skin with laps
- 5 Decorative extruded profile HF14
- 6 External pre-painted steel skin

MW H H+



OVERVIEW OF QBISS SCREEN COMPONENTS

Aluminium honeycomb core is one of the most widely used high performance honeycomb. It is chosen due to its excellent strength to weight ratio bonding characteristics and high recyclability.

Mineral wool core is made of quarried diabase rock and therefore considered as recyclable component. Water repellent role prevents water to enter the elements.

EPDM / Al corner gasket prevents the intrusion of water in the element.

Transversal gasket prevents the intrusion of water in ventilated facade system through transversal joint.

Load bearing fixing plate (1) for Qbiss Screen MW and H, with predrilled holes help position screws during the installation.

Aluminium decorative extruded profile HF 14 (2) is factory applied on all Qbiss Screen element types B-B (longitudinal joint dimension 23 mm): F-B element types are without decorative extrusion (longitudinal joint dimension is 4 mm).

Decorative extruded profile HF 40 and HF 64 (3) provide a perfect aesthetic finish of facade.

Load bearing fixing element HF 63 (4) for Qbiss Screen H+, with predrilled holes helps to position screws during installation.

Lap joint flanges with stub ends (5) are designed to withstand self-weight fixing of Qbiss Screen H and H+. Predrilled holes help position fixings during installation.



Element distribution texts

Qbiss Screen MW	Qbiss Screen H	Qbiss Screen H+
F-B / Power S / 65 mm / 900 mm	B-B / 50 mm / 1000 mm	B-B / 50 mm / 1000 mm
G - 0,70 mm	G - 0,70 mm	G - 0,70 mm
Cream - PUR-PA 50µm	Bright Yellow - PUR-PA 50µm	Bright Yellow - PUR-PA 50µm
Dark Silver - PVDF 25µm	White - PUR-PA 50µm	White - PVDF 35µm

Qbiss Screen MW	F-B	Power S	65	900	Cream	0,70	G	PUR-PA	Dark Silver	0,70	G	PVDF
product name	joint type	core	thickness (mm)	module (mm)	external steel skin colour	external steel skin thickness	external steel skin profile	external steel skin protection	internal steel skin colour	internal steel skin thickness	internal steel skin profile	internal steel skin protection



TRIMO PAVILION AT BAU 2019
GERMANY

HORIZONTAL QBISS SCREEN H

2019

MOJCA ŠAVNIK, ŠPELA LOKAR, TRIMO D.O.O.



B. ELEMENT DESCRIPTION



STEEL SKIN THICKNESS AND PROFILE

Experiences from the past lead us to perfection. Having a clean design in our mind, we achieved a perfect flatness of the external side by using 0,7 or 0,675 mm thick steel skin. On the internal side of Qbiss Screen element there is also 0,7 or 0,675 mm thick steel skin with a smooth profilation.

PROFILES

External skin thickness: 0,7 mm, 0,675 mm

Smooth profile (G)

Internal skin thickness: 0,7 mm, 0,675 mm

Smooth profile (G)



G - profilation (external skin)



COLOUR YOUR DESIGN

With exceptional technical characteristics and perfect visual expression, Trimo façade system easily adjusts to your vision of space. To meet our customers' needs, we prepared a range of colour coatings, suitable for external and internal side of Qbiss Screen elements.

Colour range does not in any case define delivery terms or any other terms of specific skin colour. Colours presented show only a fraction of most usable colours within the variety of colours available.

SOLID COLOURS

TRIMO COLOUR	NEAREST RAL OR OTHER REFERENCE COLOUR
 WHITE	RAL 9010
 GREY WHITE	RAL 9002
 LIGHT GRAY	RAL 7035
 CREAM	RAL 1015
 BASALT GREY	RAL 7012
 SAPPHIRE BLUE	RAL 5003
 TRAFFIC RED	RAL 3020
 ANTHRACITE	RAL 7016
 BLACK	RAL 9005



SPECIAL METALLIC

 SILVER	RAL 9006
 LIGHT SILVER	N/A
 DARK SILVER	RAL 9007
 LIGHT GRAPHITE	N/A

- Colours may slightly deviate due to different monitors and prints compared to original colours. On request Trimo will send you a metal swatch.
- Full terms and conditions of the Confidex® Guarantee are available on the on-line application form, available at www.colorcoat-online.com/registration
- Confidex® must be registered within 3 months of the building completion date for the guarantee to be valid.
- The Confidex® Guarantee periods on the diagram on the right are applicable to Zone 1. For more information on other zones visit: www.colorcoat-online.com/confidexmap.



COLORCOAT PRISMA® ELEMENTS*

TRIMO COLOUR	NEAREST RAL OR OTHER REFERENCE COLOUR
 SIRIUS SPARKLE	Colorcoat Prisma® COLOUR
 ORION SPARKLE	Colorcoat Prisma® COLOUR
 ZEUS SPARKLE	Colorcoat Prisma® COLOUR
 SEREN WHITE	Colorcoat Prisma® COLOUR
 SEREN SILVER	Colorcoat Prisma® COLOUR
 SEREN GOLD	Colorcoat Prisma® COLOUR

TRIMO COLOUR	NEAREST RAL OR OTHER REFERENCE COLOUR
 SEREN COPPER	Colorcoat Prisma® COLOUR
 SEREN BLACK	Colorcoat Prisma® COLOUR
 SEREN ANTHRACITE	Colorcoat Prisma® COLOUR
 SEREN MIDAS	Colorcoat Prisma® COLOUR
 SEREN TITAN	Colorcoat Prisma® COLOUR

* Colorcoat Prisma and Seren are trademarks of Tata Steel UK Limited.

STAINLESS STEEL

On a project by project individual basis Trimo can provide a bespoke solution of Qbiss façades from stainless steel in order to preserve the long-term value of the building and provide unique architectural solution & appearance. Availability and application shall be discussed with Trimo technical department.

 QUADRO LUCIDO	 DOTS LUCIDO
 2WL LUCIDO	 5WL LUCIDO
 PELLE LUCIDO	



Regions covered by the Confidex® Guarantee

Zone 1 / Northern Europe **Zone 2** / Southern Europe
For areas outside of Confidex® zones please contact Tata Steel for more information.

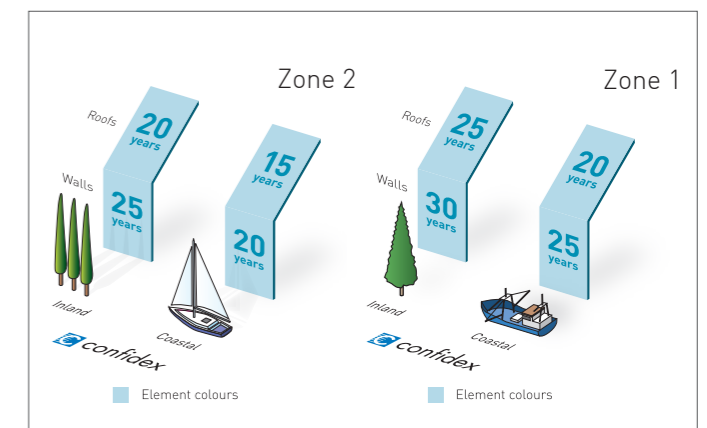

Note
Figures under the Coastal heading are for buildings within 1 km of any coast (Only valid for Qbiss One and Qbiss Screen MW).
The Confidex® Guarantee is applicable for the weatherside (directly exposed to rain and sun) steel skin.



CORROSION ATMOSPHERE STEEL SKIN PROTECTION

Type of corrosion protection		External steel skin			Internal steel skin					
		PVDF	PVDF+	PUR/PA	SP	PVDF	PVDF+	PUR/PA	PVC(P)	PVC(F)
Total organic thickness (µm) [EN 13523-1]		25	35-57	50	25	25	35-57	50-65	175-200	120-150
Corrosion resistance category	External EN 10169	RC3	RC4	RC5	-	-	-	-	-	-
	Internal EN 10169	-	-	-	CPI3	CPI3	CPI5	CPI5	CPI5	CPI3
Types of outdoor atmosphere corrosivity category	Rural - normal	C2	••••	••••	••••	••••	••••	••••	••••	••••
	Urban and light industrial (low SO ₂)	C3	••••	••••	••••	••	••••	••••	••••	••••
	Industrial (Moderate SO ₂)	C4		•••	•••		•••	••••	••••	••••
	marine 0 < 5 km from sea	C5-M	Internal use only	•	•	Internal use only	Internal use only	•	•	••••
	marine > 5 km from the sea	C5-M	Internal use only	•	•••	Internal use only	Internal use only	•	•••	••••
Severe industrial	C5-I		•	•		•	•	••••	••••	
Temperature resistance (°C)		110	110	110	80	110	110	110	60	60
UV resistance category [EN 13523-10]		Ruv4	Ruv4	Ruv4	Ruv3	Ruv4	Ruv4	Ruv4	Ruv2	-
Flexibility		•••	••••	••••	••	•••	••••	••••	••••	••••
Staining resistance		••••	••••	••••	•••	••••	••••	••••	••	••••

- Suitable without limitations
- Very suitable
- Suitable
- Contact Trimo for consultancy
- Unsuitable

- Instant cooling to the dew-point temperature during cleaning procedures is forbidden as there is a danger of condensation!
- The corrosive resistance class must be defined after consideration of outdoor conditions. Standardized outdoor environment climates: C1, C2, C3, C4, C5 M, and C5 I. Example outdoor atmosphere C3 > select sheet metal with a stability class RC3 or RC4.
- Recommended use - north of the 45 north latitude parallel [T_{max} 70 °C].

* Only for mineral wool core elements

CORROSION PROTECTION

We don't accept anything less than the best for our products. The most harmful part of the element is the weather side. It is exposed to environment impact, therefore it must be well protected in order to last long. We discuss corrosion with confidence. Only pre-painted steel skin with the best protection on the market is being used to produce our ventilated façade elements. The weather side of Qbiss Screen element is protected with PUR/PA or PVDF protection. For the most optimal results we can adjust protection of the element's internal face based on the building purpose.

CORE

Core element of Qbiss Screen has 2 different options. Its main purpose is to obtain excellent strength of the element and to reach long spans.

HONEYCOMB

A very thin metal aluminium perforated foil (50 µm) is formed into a hexagonal honeycomb structure with the 3/4" cell size making the element the lightest possible.

Honeycomb provides the most efficient loadbearing capacity, stiffness and shear strength of an element. Aluminium honeycomb used in Qbiss Screen is corrosion resistant and at the same time environmentally friendly by being 100% recyclable.

Due to its high thermal conductivity, honeycomb equalizes the deflection from temperature load very quickly.

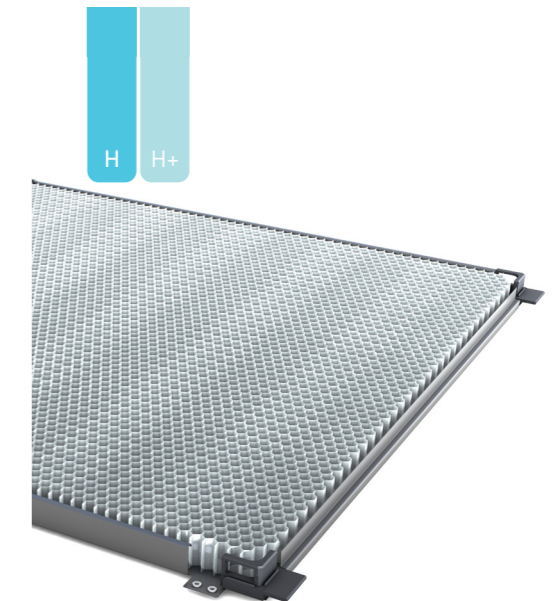

Honeycomb provides efficient loadbearing capacity, stiffness and shear strength of Qbiss Screen H and H+ element.

MINERAL WOOL

Core constituent of Qbiss Screen MW element is mineral wool. It is an insulation material made from melted stone of volcanic origin and then fiberized. It is considered as recyclable component. Water repellent role prevents water to enter the element. The main purpose of mineral wool in Qbiss Screen is to get an excellent element strength to resist wind loads.



MEASUREMENTS

MEASUREMENTS

The basic element of Qbiss Screen is a modular ventilated façade element, which is made by an automated and robotic production line. Pre-finished steel sheets are bonded to the core, made of mineral wool or aluminium honeycomb. All three layers form a solid prefabricated ventilated façade element.

Qbiss Screen element is defined by the raster length - R and the module width of the façade element - M. In the façade installation, the elements form the longitudinal and transversal joint. All values are stated in millimeters.

Qbiss Screen MW
B-B horizontal element

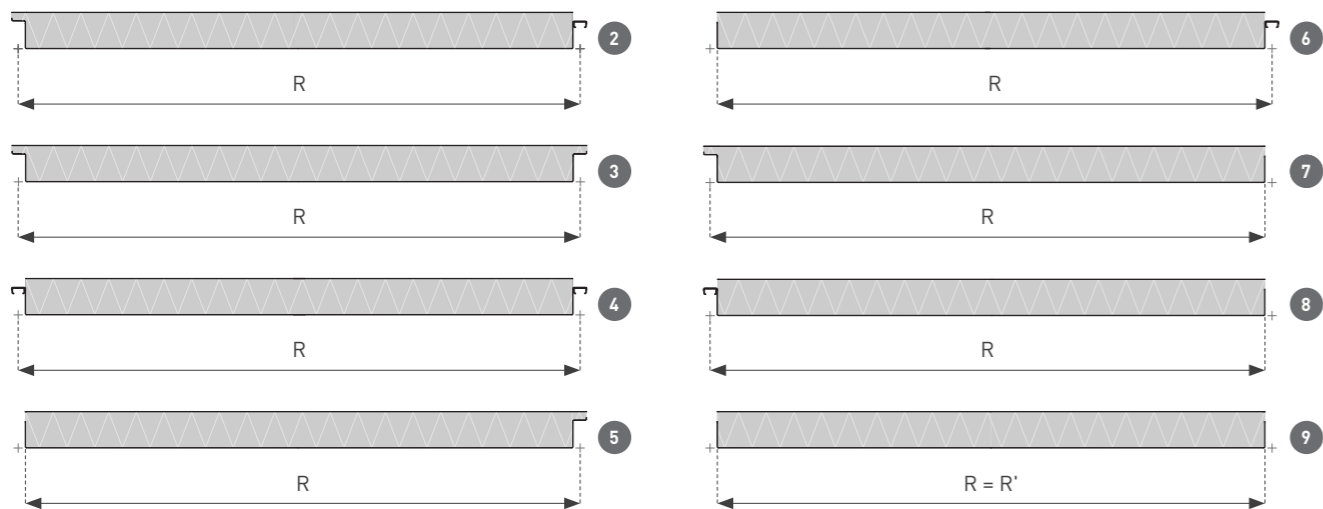
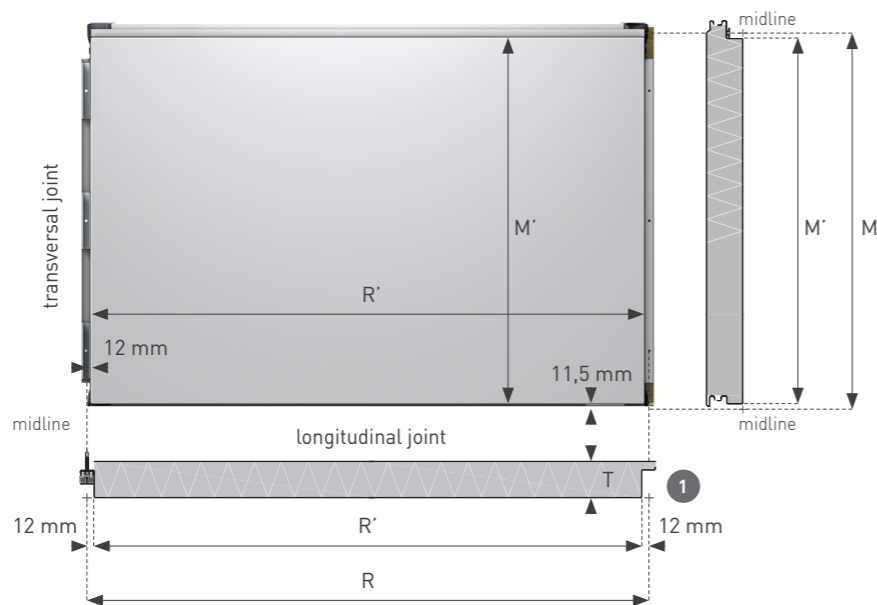

- T - Qbiss Screen element thickness
- R - Design length
- R' - Qbiss Screen element face length
- M - Module width
- M' - Qbiss Screen element face width
- ② - Qbiss Screen element type

[Link to all element types chapter](#)

Qbiss Screen H
B-B horizontal element

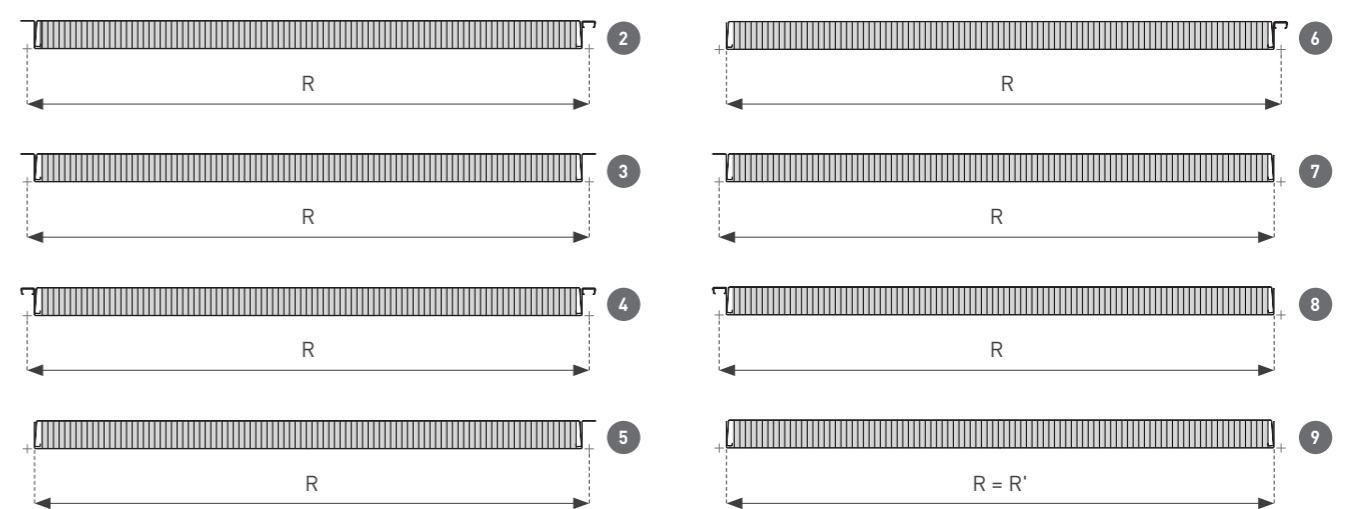
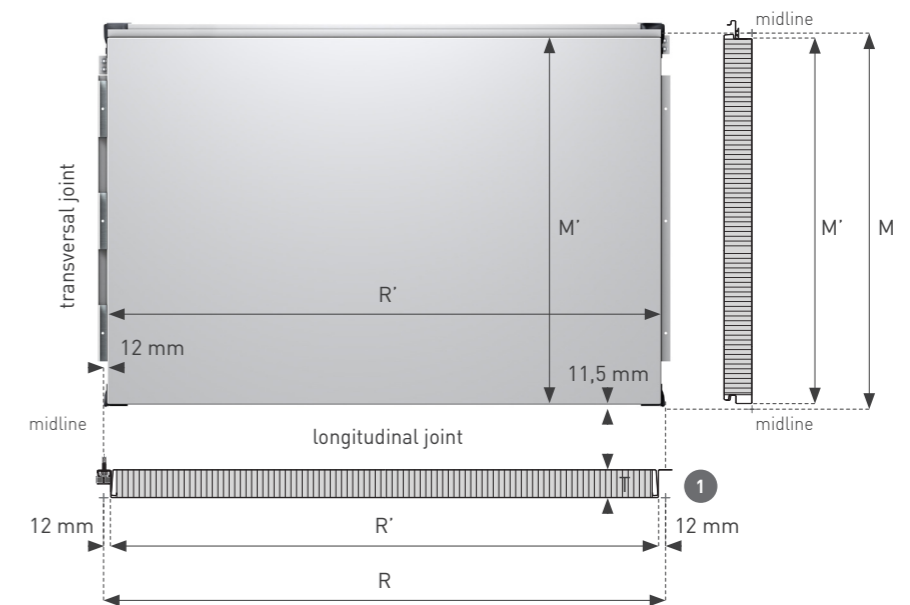

- T - Qbiss Screen element thickness
- R - Design length
- R' - Qbiss Screen element face length
- M - Module width
- M' - Qbiss Screen element face width
- ② - Qbiss Screen element type

[Link to all element types chapter](#)

Qbiss Screen H+
B-B horizontal element

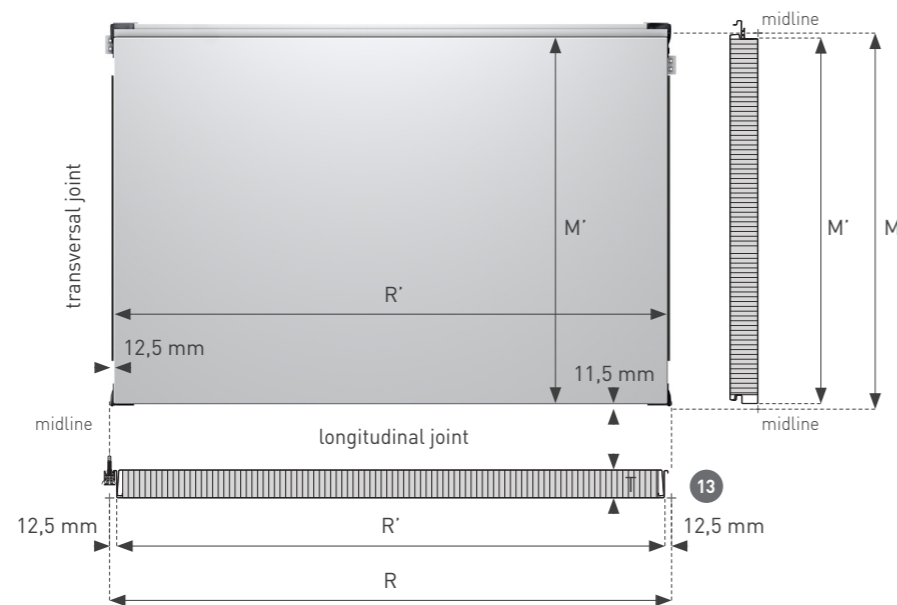

- T - Qbiss Screen element thickness
- R - Design length
- R' - Qbiss Screen element face length
- M - Module width
- M' - Qbiss Screen element face width
- 2 - Qbiss Screen element type

TECHNICAL DATA

TECHNICAL DATA FOR QBISS SCREEN FAÇADE ELEMENTS

Qbiss Screen elements are differentiated based on core material and joint shape.

PROPERTIES	TECHNICAL DATA		
Facade element	QBISS SCREEN MW	QBISS SCREEN H	QBISS SCREEN H+
Element thickness (mm)	65	50	50
Element width (mm)	Available 600-1200	Available 600-1200	Available 600-1200
Element length (mm)	500 - 6500 * ***	550 - 6500 *	550 - 6500 *
External / Internal skin (side A / side B)	Steel skin, smooth (G)	Steel skin, smooth (G)	Steel skin, smooth (G)
Coating (external steel skin)	Coating PVDF or PUR/PA		
Core	Mineral wool	Aluminium honeycomb	Aluminium honeycomb
Core combustibility (EN 13501-1; EN 13823)	Non-combustible Class A1	Non-combustible Class A1	Non-combustible Class A1
Element weight (kg/m²)	19,9	15,6**	15,1**
Reaction to fire (EN 13501-1)	A2-s1, d0	up to A2-s1, d0	up to A2-s1, d0

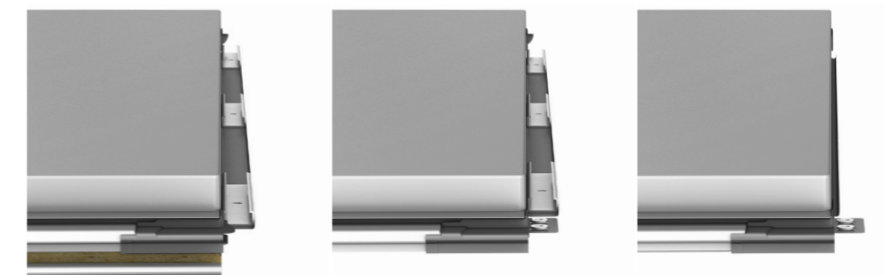

- * Element length depends on the design requirements consistent with the structural analysis and the mechanical characteristics of the Qbiss Screen element.
- ** Weight of Qbiss Screen H and H+ façade element considers element dimension of [R x M] 1000 mm x 1000 mm and thickness of external / internal steel skin 0,7 / 0,7 mm. For specific individual project requirements please contact Trimo technical support.
- *** Qbiss Screen MW: the minimum length is set to 550 mm and the maximum length to 6475 mm for the element types: 5, 6, 7, 8, 9.

! Values of the table may differ due to different legislation in individual countries.



C. ACCESSORIES

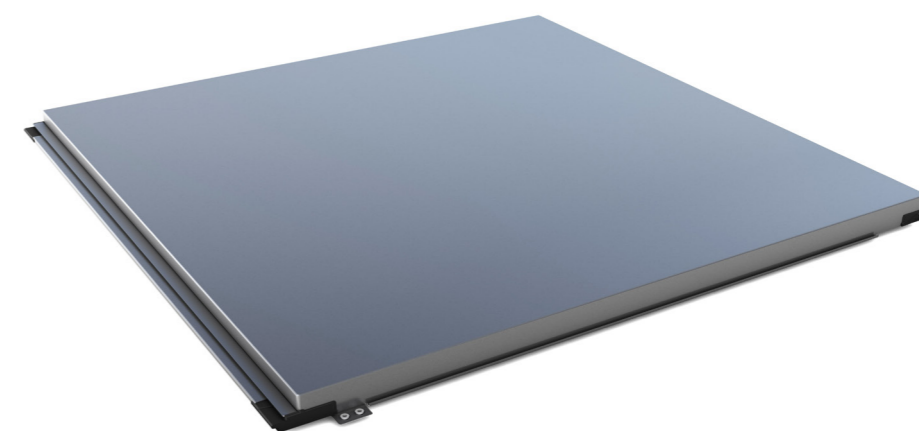

CORNER ELEMENTS

UNIQUENESS OF QBISS SCREEN ELEMENTS

Prefabrication is the uniqueness of Qbiss Screen. In addition to rectangular elements, we produce corner elements as well as spliced corner elements, connecting two different façades or façade prolonging directly into a soffit. Different colours of corner sides are also an option. While designing, you need to take into consideration production limitations.

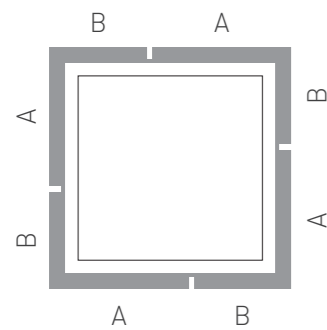

The principle for designating the sides of corner elements.

Presented is a plan view of four corners of a building with side designations.

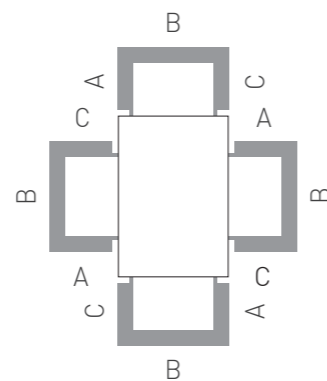

The principle for designating the sides of U-corner elements.

Presented is a plan view of four corners of a building with side designations.

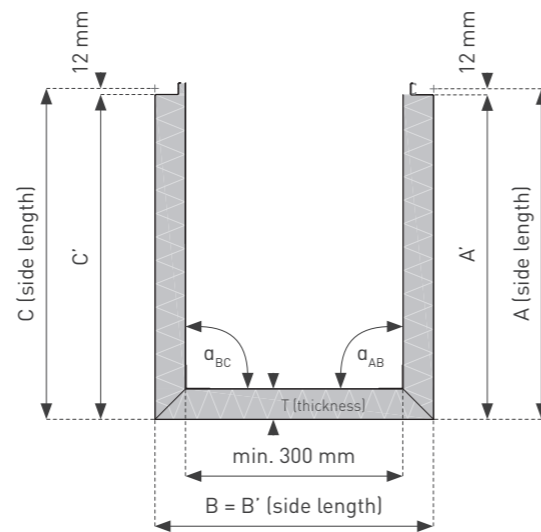
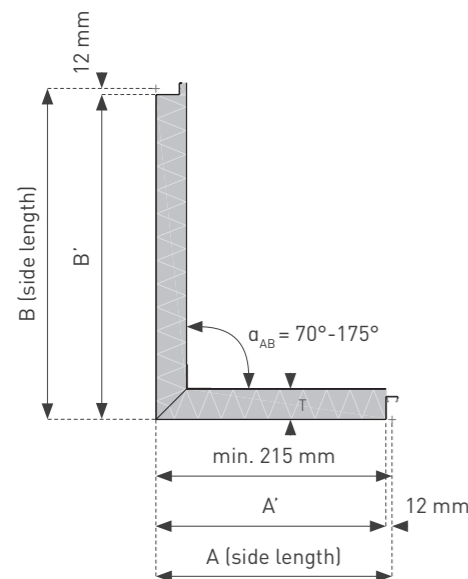

Qbiss Screen MW transversal and U corner element.



Qbiss Screen longitudinal corner element completing building envelope.

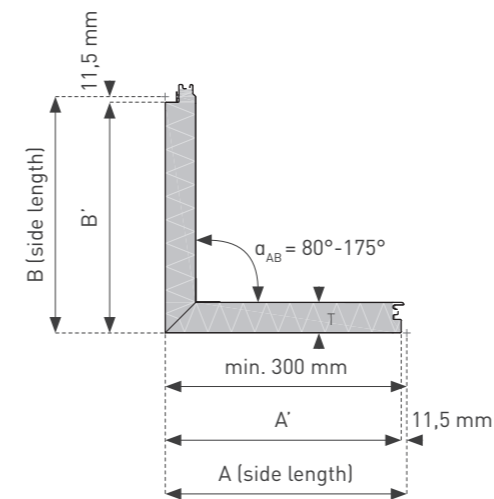

Qbiss Screen MW longitudinal corner element.

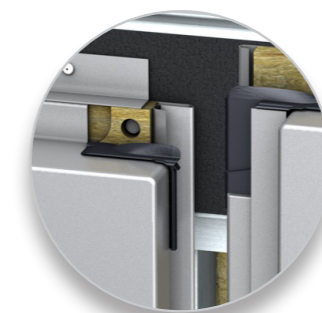

- R – Design length
- M – Module width
- T – Qbiss Screen element thickness

! All variations of corner elements are produced out of a flat Qbiss Screen elements. Finalization of each corner is performed outside robotized production line, therefore minor deviation in product tolerances, surface inconsistencies and local change in appearance might occur.

Direction of installation and the element type do not affect the designation of legs (A, B, C) of the corner element.

Scheme for designating the corner sides is presented on the previous page.

TRANSVERSAL CORNER ELEMENT LIMITATIONS

Restrictions on the length of the corner elements sides

- $(A+B)_{min} = 500 \text{ mm}$
- $A_{min} (B_{min}) = 215 \text{ mm}$
- $A_{max} (B_{max}) = 1000 \text{ mm}$
- $\alpha_{AB} = 70^\circ - 175^\circ$
- $M = 600 \text{ mm} - 1200 \text{ mm}$
- $T = 65 \text{ mm}$

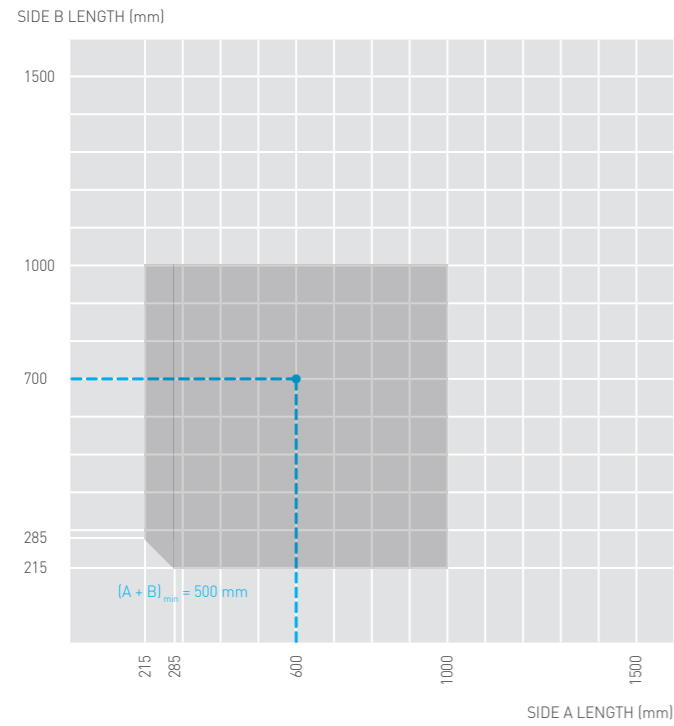

TRANSVERSAL U-CORNER ELEMENT LIMITATIONS

Restrictions on the length of the U-corner elements sides

- $A_{min} (C_{min}) = 215 \text{ mm}$
- $B_{min} = 430 \text{ mm}$
- $A_{max} = B_{max} = C_{max} = 1000 \text{ mm}$
- $\alpha_{AB}, \alpha_{BC} = 90^\circ - 175^\circ$
- $M = 600 \text{ mm} - 1200 \text{ mm}$
- $T = 65 \text{ mm}$

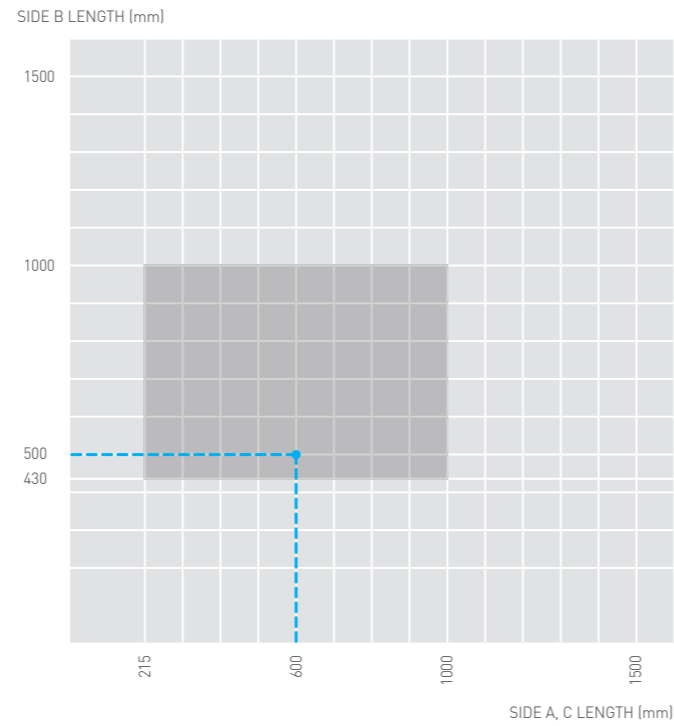

LONGITUDINAL CORNER ELEMENT LIMITATIONS

Restrictions on the length of the corner elements sides

- $A_{min} (B_{min}) = 300 \text{ mm}$
- $A_{max} (B_{max}) = 900 \text{ mm}$
- $\alpha_{AB} = 80^\circ - 175^\circ$
- $M (A+B) = 600 \text{ mm} - 1200 \text{ mm}$
- $R = 500 \text{ mm} - 6500 \text{ mm}$
- $T = 65 \text{ mm}$

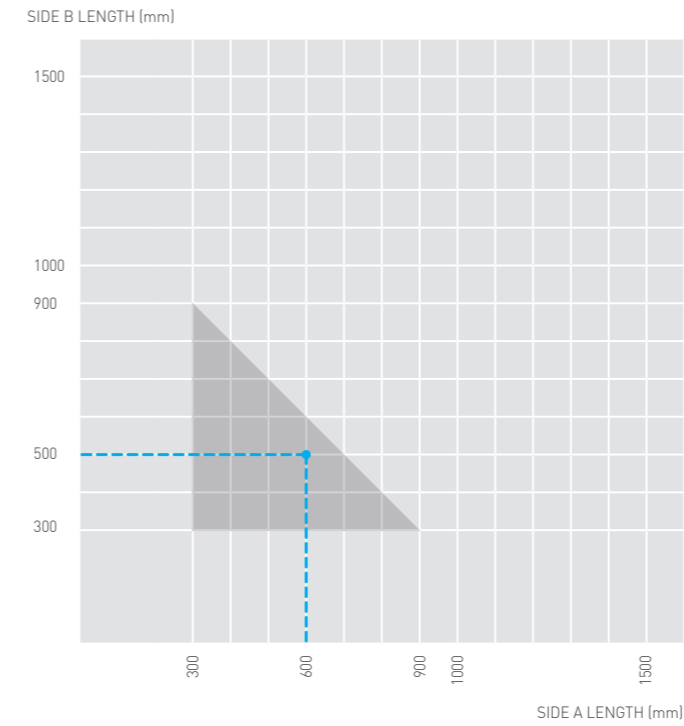

* Corner sides (legs) definition example.

R – Design length
M – Module width
T – Qbiss Screen element thickness

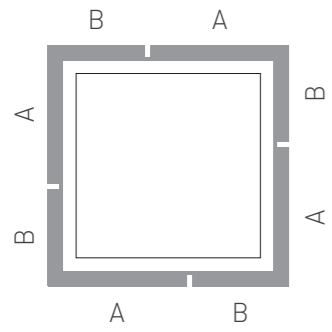

The principle for designating the sides of corner elements.

Presented is a plan view of four corners of a building with side designations.

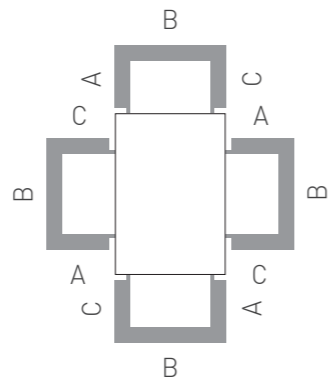

The principle for designating the sides of U-corner elements.

Presented is a plan view of four corners of a building with side designations.

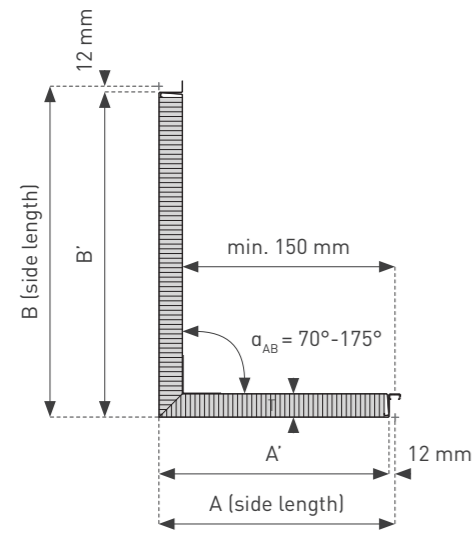

Qbiss Screen H transversal corner element.



Lap joint flanges mid position



Lap joint flanges bottom position

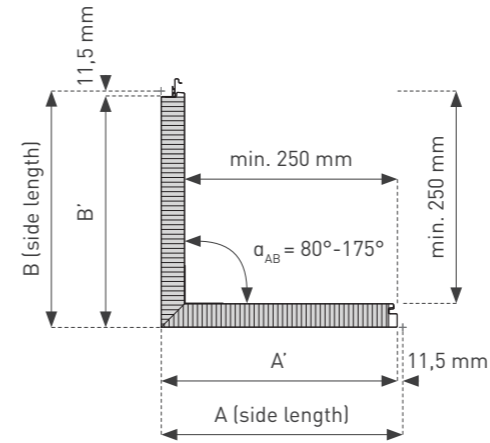

Qbiss Screen H longitudinal corner element.



Lap joint flanges - upper position



Lap joint flanges mid position

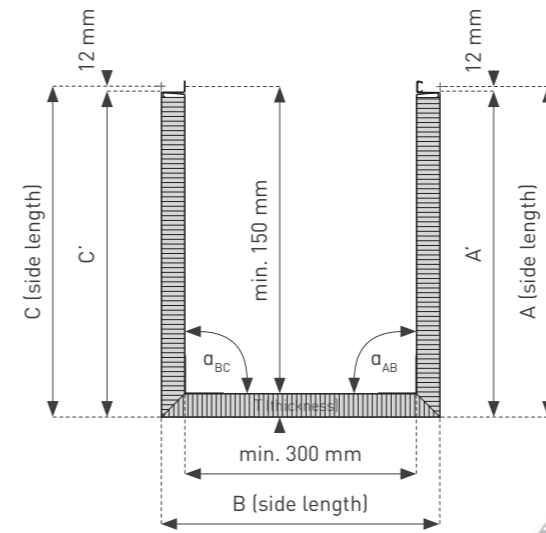

Qbiss Screen H U corner element.



Lap joint flanges mid position



Lap joint flanges bottom position

- R – Design length
- M – Module width
- T – Qbiss Screen element thickness

TRANSVERSAL CORNER ELEMENT LIMITATIONS

Restrictions on the length of the corner elements sides

- $A_{min} (B_{min}) = 200 \text{ mm}$
- $A_{max} (B_{max}) = 1000 \text{ mm}$
- $(A + B)_{min} = 550 \text{ mm}$
- $A' (B') = A (B) - 12,5 \text{ mm}$
- $\alpha_{AB} = 70^\circ - 175^\circ$
- $M = 600 \text{ mm} - 1200 \text{ mm}$
- $T = 50 \text{ mm}$

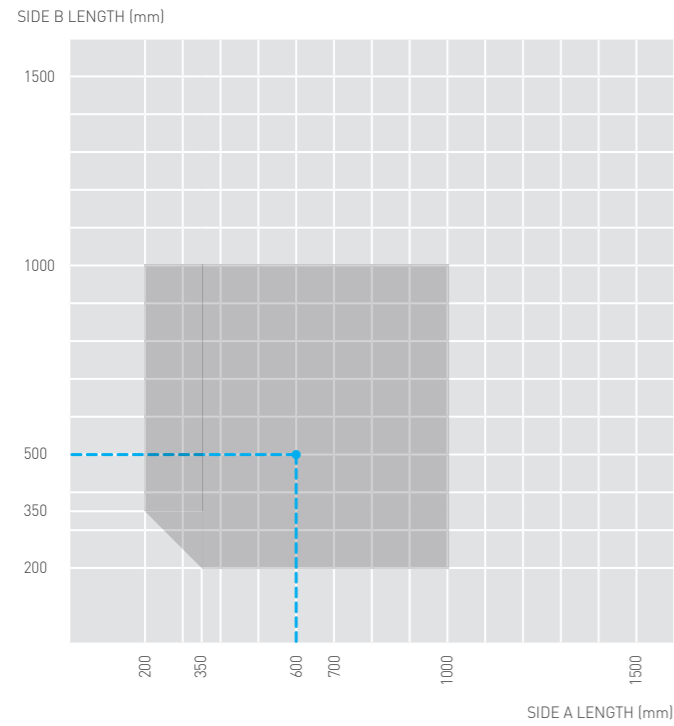

TRANSVERSAL U-CORNER ELEMENT LIMITATIONS

Restrictions on the length of the U-corner elements sides

- $A_{min} (C_{min}) = 200 \text{ mm}$
- $B_{min} = 400 \text{ mm}$
- $A_{max} = B_{max} = C_{max} = 1000 \text{ mm}$
- $\alpha_{AB}, \alpha_{BC} = 90^\circ - 175^\circ$
- $M = 600 \text{ mm} - 1200 \text{ mm}$
- $T = 50 \text{ mm}$

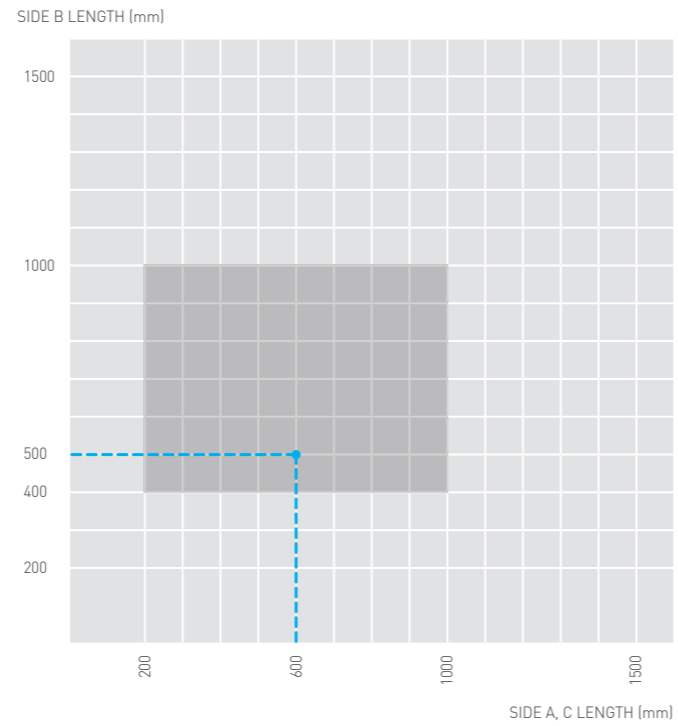

LONGITUDINAL CORNER ELEMENT LIMITATIONS

Restrictions on the length of the corner elements sides

- $A_{min} (B_{min}) = 300 \text{ mm}$
- $A_{max} (B_{max}) = 900 \text{ mm}$
- $A' (B') = A (B) - 11,5 \text{ mm}$
- $\alpha_{AB} = 80^\circ - 175^\circ$
- $R = 550 \text{ mm} - 6500 \text{ mm}$
- $M = 600 \text{ mm} - 1200 \text{ mm}$
- Qbiss Screen H B-B: $M = A' + B' + 23 \text{ mm}$
- $T = 50 \text{ mm}$

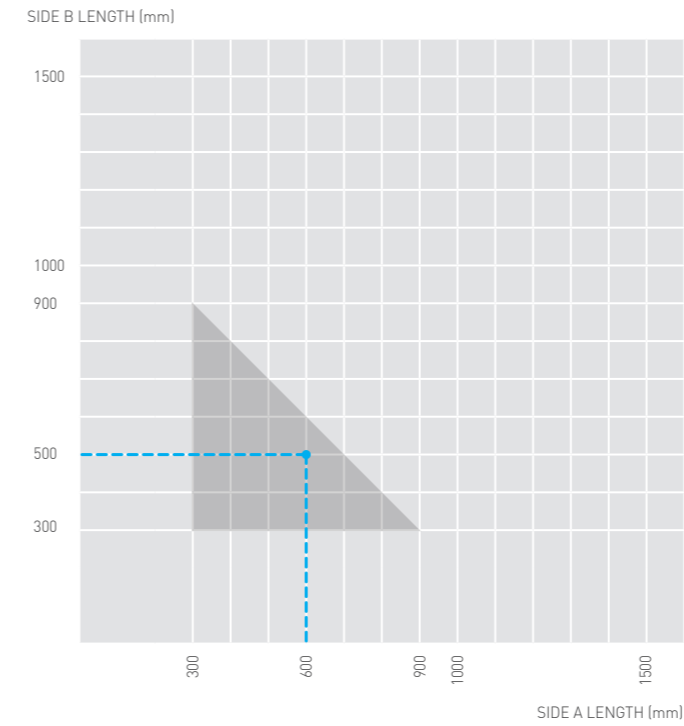

* Corner sides (legs) definition example.

R – Design length
 M – Module width
 T – Qbiss Screen element thickness

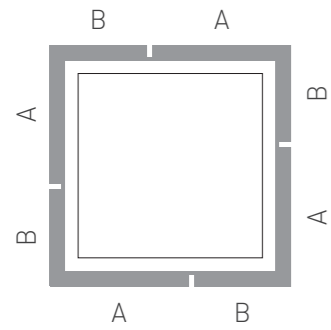

The principle for designating the sides of corner elements.

Presented is a plan view of four corners of a building with side designations.

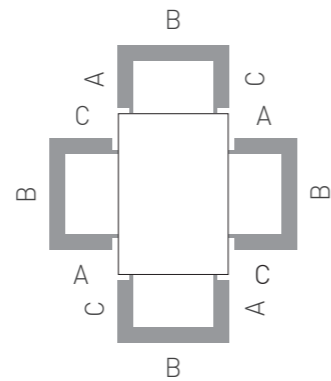

The principle for designating the sides of U-corner elements.

Presented is a plan view of four corners of a building with side designations.

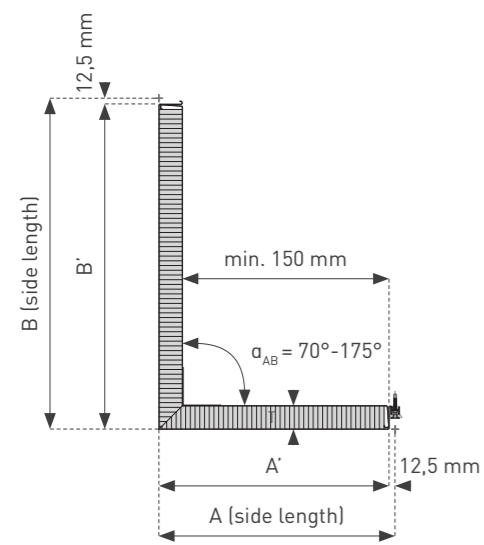

Qbiss Screen H+ transversal corner element.

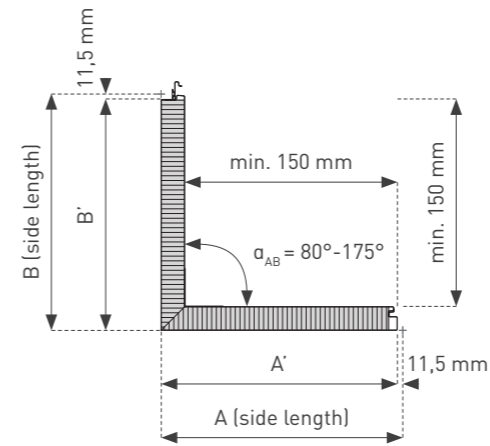

Qbiss Screen H+ longitudinal corner element.

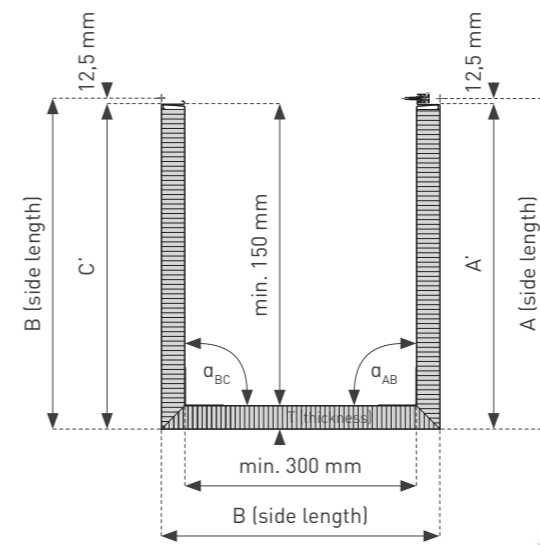
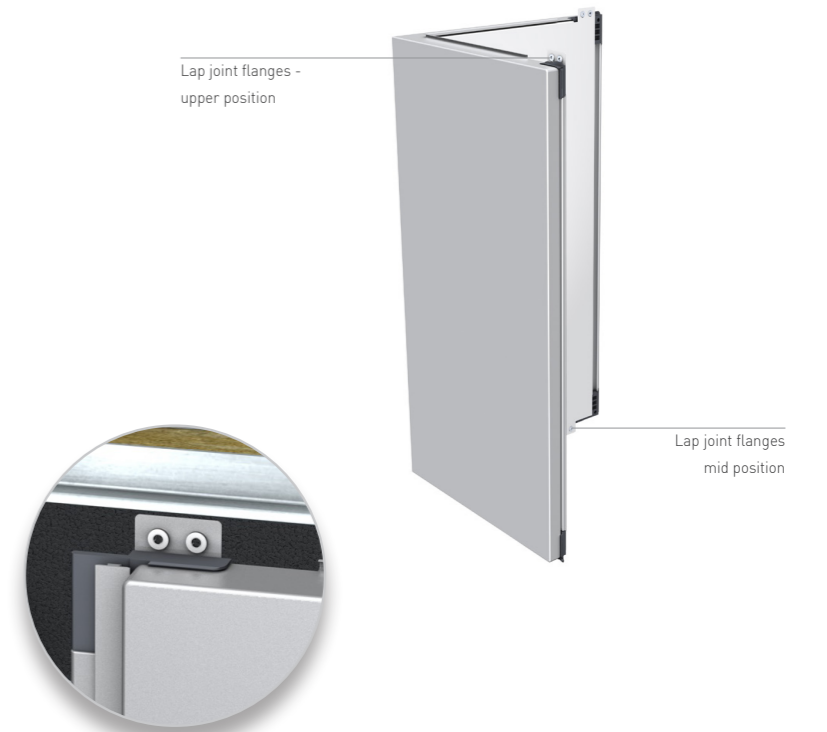

Qbiss Screen H+ U-shaped corner element.



- R – Design length
- M – Module width
- T – Qbiss Screen element thickness

TRANSVERSAL CORNER ELEMENT LIMITATIONS

Restrictions on the length of the corner elements sides

- $A_{min} (B_{min}) = 200 \text{ mm}$
- $A_{max} (B_{max}) = 1000 \text{ mm}$
- $(A + B)_{min} = 550 \text{ mm}$
- $A' (B') = A (B) - 12,5 \text{ mm}$
- $\alpha_{AB} = 70^\circ - 175^\circ$
- $M = 600 \text{ mm} - 1200 \text{ mm}$
- $T = 50 \text{ mm}$

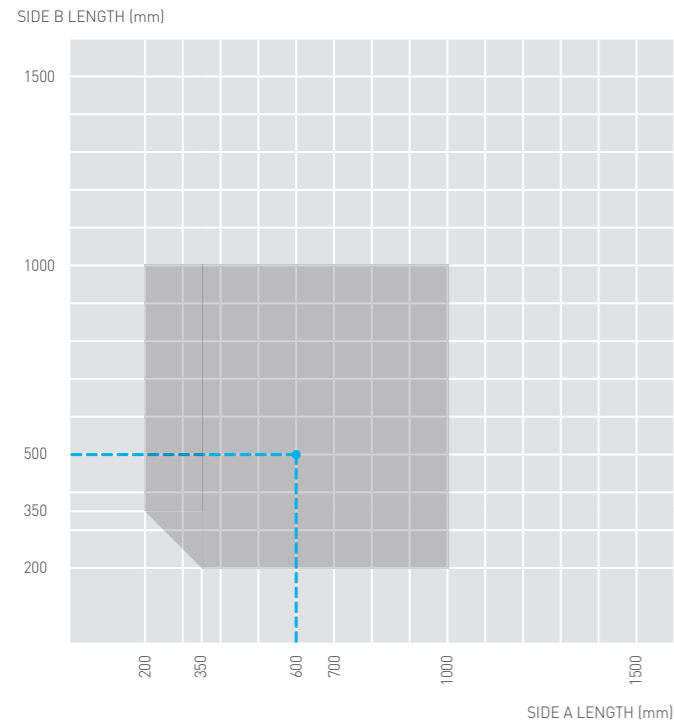

* Corner sides (legs) definition example.

TRANSVERSAL U-CORNER ELEMENT LIMITATIONS

Restrictions on the length of the U-corner elements sides

- $A_{min} (C_{min}) = 200 \text{ mm}$
- $B_{min} = 400 \text{ mm}$
- $A_{max} = B_{max} = C_{max} = 1000 \text{ mm}$
- $\alpha_{AB}, \alpha_{BC} = 90^\circ - 175^\circ$
- $M = 600 \text{ mm} - 1200 \text{ mm}$
- $T = 50 \text{ mm}$

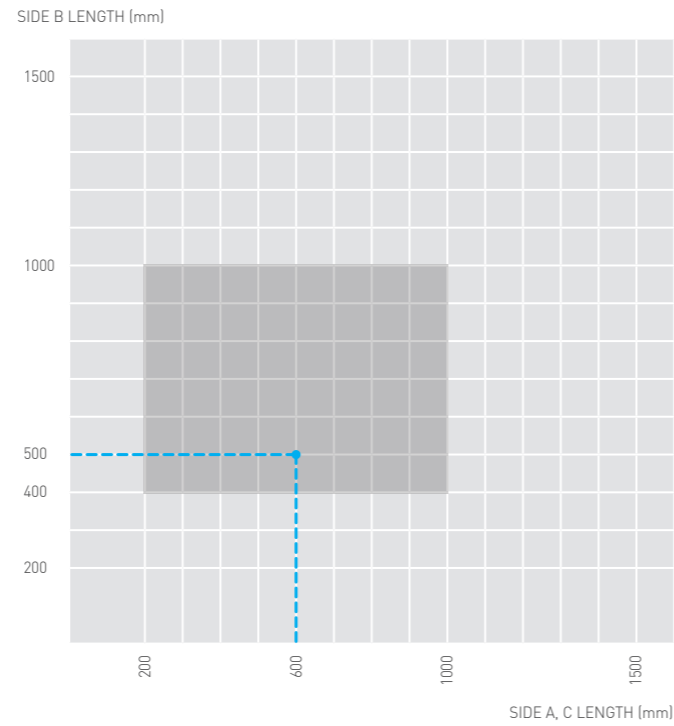

LONGITUDINAL CORNER ELEMENT LIMITATIONS

Restrictions on the length of the corner elements sides

- $A_{min} (B_{min}) = 300 \text{ mm}$
- $A_{max} (B_{max}) = 900 \text{ mm}$
- $A' (B') = A (B) - 11,5 \text{ mm}$
- $\alpha_{AB} = 80^\circ - 175^\circ$
- $R = 550 \text{ mm} - 4000 \text{ mm}$
- $M = 600 \text{ mm} - 1200 \text{ mm}$
- $T = 50 \text{ mm}$

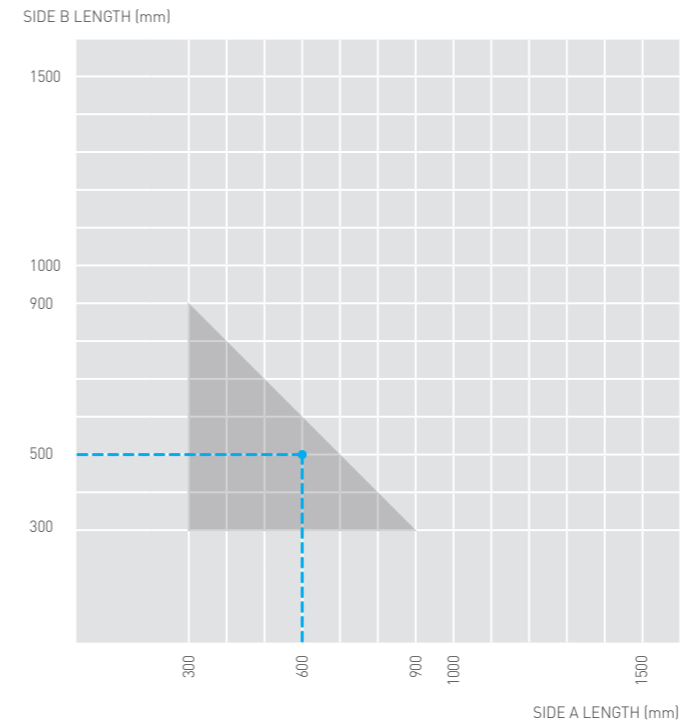

R – Design length
 M – Module width
 T – Qbiss Screen element thickness

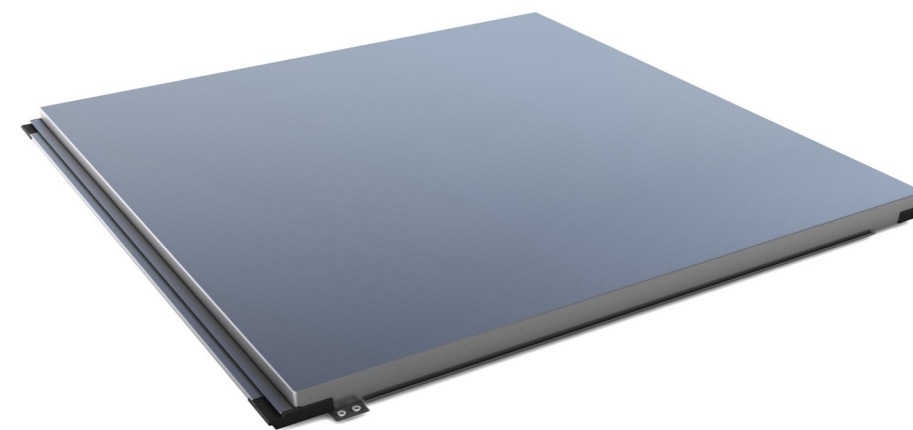

SYSTEM COMPOSITION

VENTILATED FAÇADE

Ventilated façades consist of several materials and a ventilation cavity (air gap). They usually incorporate thermal insulation, but there are also façade walls without thermal insulation. The calculation shows the need for a vapor barrier in individual cases, and the need for wind barrier depends on the choice of thermal insulation. In addition to adjusting temperature differences, the air cavity on the façade also serves to dry excess moisture that accumulates in the ventilation cavity from the inside or the outside. This is especially important when renovating older buildings and other buildings with loadbearing walls of porous materials such as various types of bricks, aerated concrete, sand-lime block, etc.

GENERAL

Qbiss Screen system is a metal rainscreen, where, besides the aesthetic function, it performs a protective function - the protection of the façade envelope against atmospheric effects. Ventilated façades are divided into those with thermal insulation and those without thermal insulation. The element module size and joint gap appearance can vary to the project requirements within production limits.

SUMMER DAYTIME PERFORMANCE

- OUTLET VENTS OPEN
- FIRE STOPS AT FLOOR SLAB EDGES
- INTERNAL STRUCTURAL WALL
- QBISS SCREEN EXTERNAL PRE-PAINTED STEEL SKIN
- QBISS SCREEN TRANSVERSAL GASKET
- ALUMINIUM SUBSTRUCTURE
- THERMAL INSULATION FOR VENTILATED FAÇADE
- AIR CAVITY
- QBISS SCREEN INTERNAL PRE-PAINTED STEEL SKIN
- STEEL SKIN VENTS AND INSECT PROTECTION



outdoor temperature

OUTDOOR

INDOOR



indoor temperature

Schematic view of a ventilated façade – with air, temperature and water flow.



Trimo provides Qbiss Screen rainscreen only (the external rainscreen system element layer).

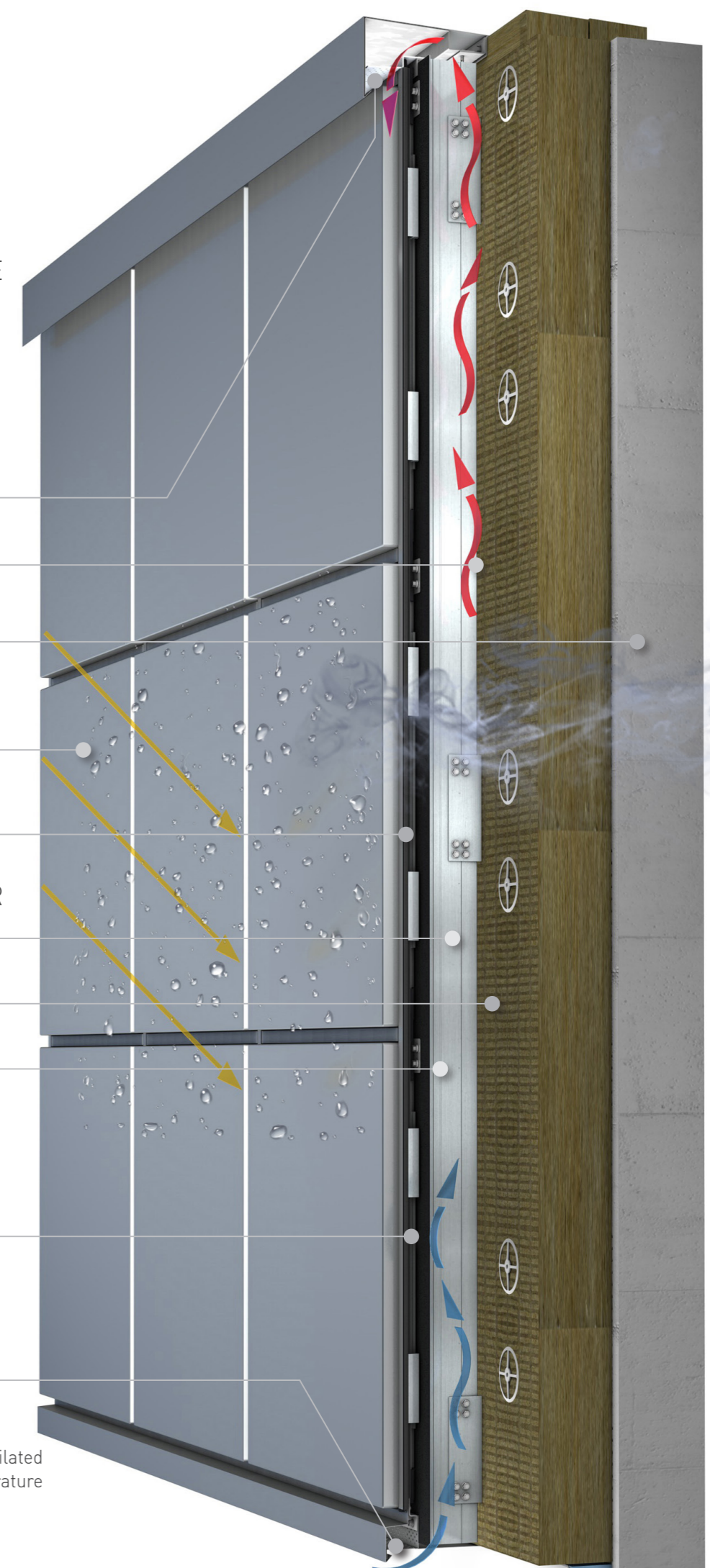

COMPLETE BUILDING ENVELOPE SYSTEM

Qbiss Screen is a modular façade metal element for ventilated façades. The architectural façade has a flat surface with recessed or flush joints. Composition of materials give elements visibly higher level of surface flatness, high load-bearing capacity, minimal thermal expansion, thermal deflection and it is insensitive to humidity. Prefabricated joints are intended to position elements relative to each other and to fix the element with screws precisely.

Qbiss Screen MW B-B horizontal element joint detail with dimensions.



closed element corners

- 1 Electrochemical potential isolation tape
- 2 Thermal insulation for ventilated façade
- 3 Decorative extrusion and transversal gasket
- 4 Drip flashing of four Qbiss Screen elements
- 5 Fixing screw
- 6 Load bearing fixing plate
- 7 Corner gasket

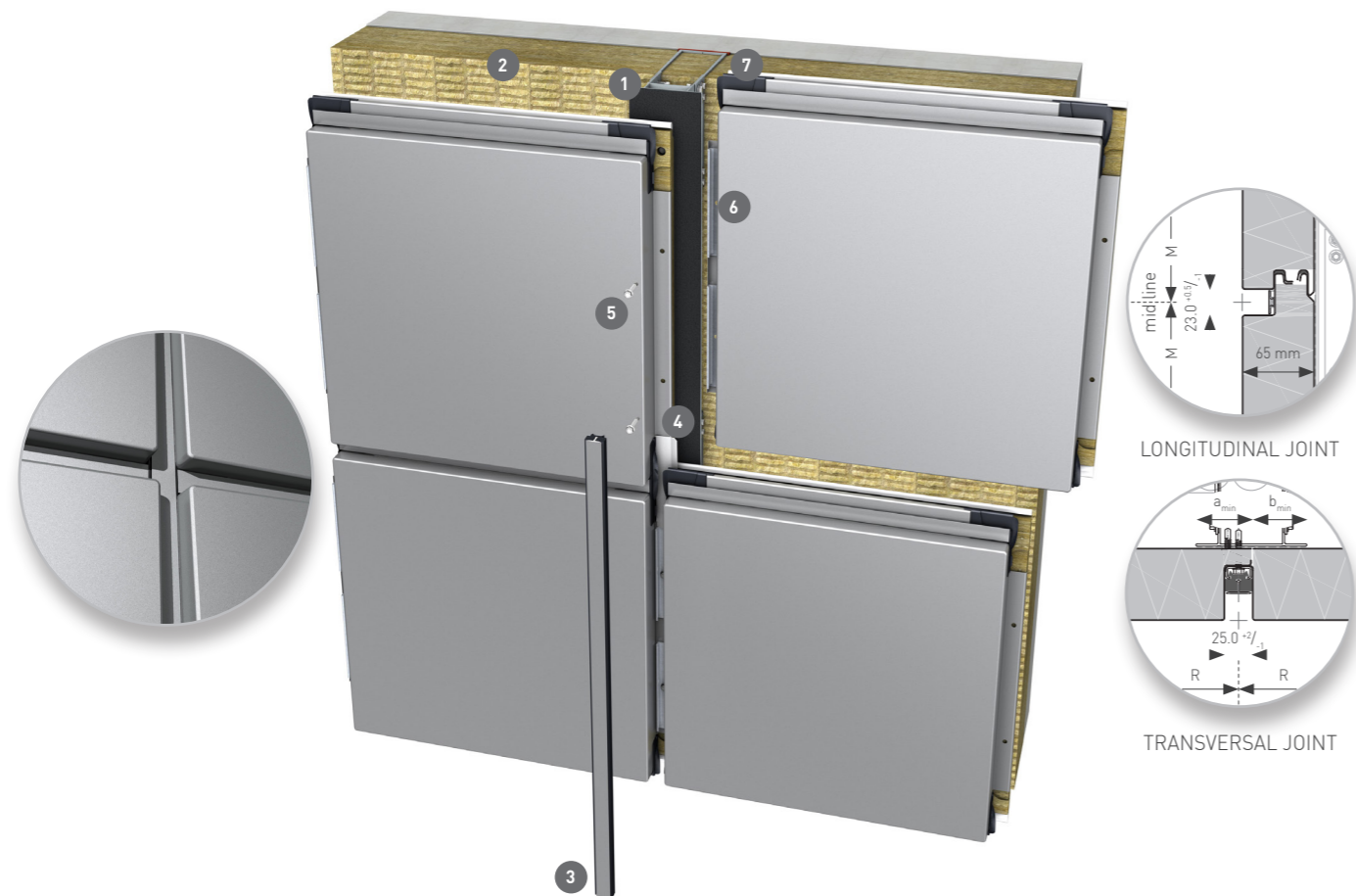

COMPONENTS OF THE SYSTEM

- Modular façade elements
- Fixing and sealing material
- Standard metal sheet flashing
- Joint interface detail for windows and doors
- Corner elements

Minimal width of element support ($a_{min} = b_{min} = 50 \text{ mm}$)

[Link to various installation methods chapter](#)

Qbiss Screen MW F-B horizontal element joint detail with dimensions.

- 1 Electrochemical potential isolation tape
- 2 Thermal insulation for ventilated façade
- 3 Decorative extrusion and transversal gasket
- 4 Drip flashing of four Qbiss Screen elements
- 5 Fixing screw
- 6 Load bearing fixing plate
- 7 Corner gasket

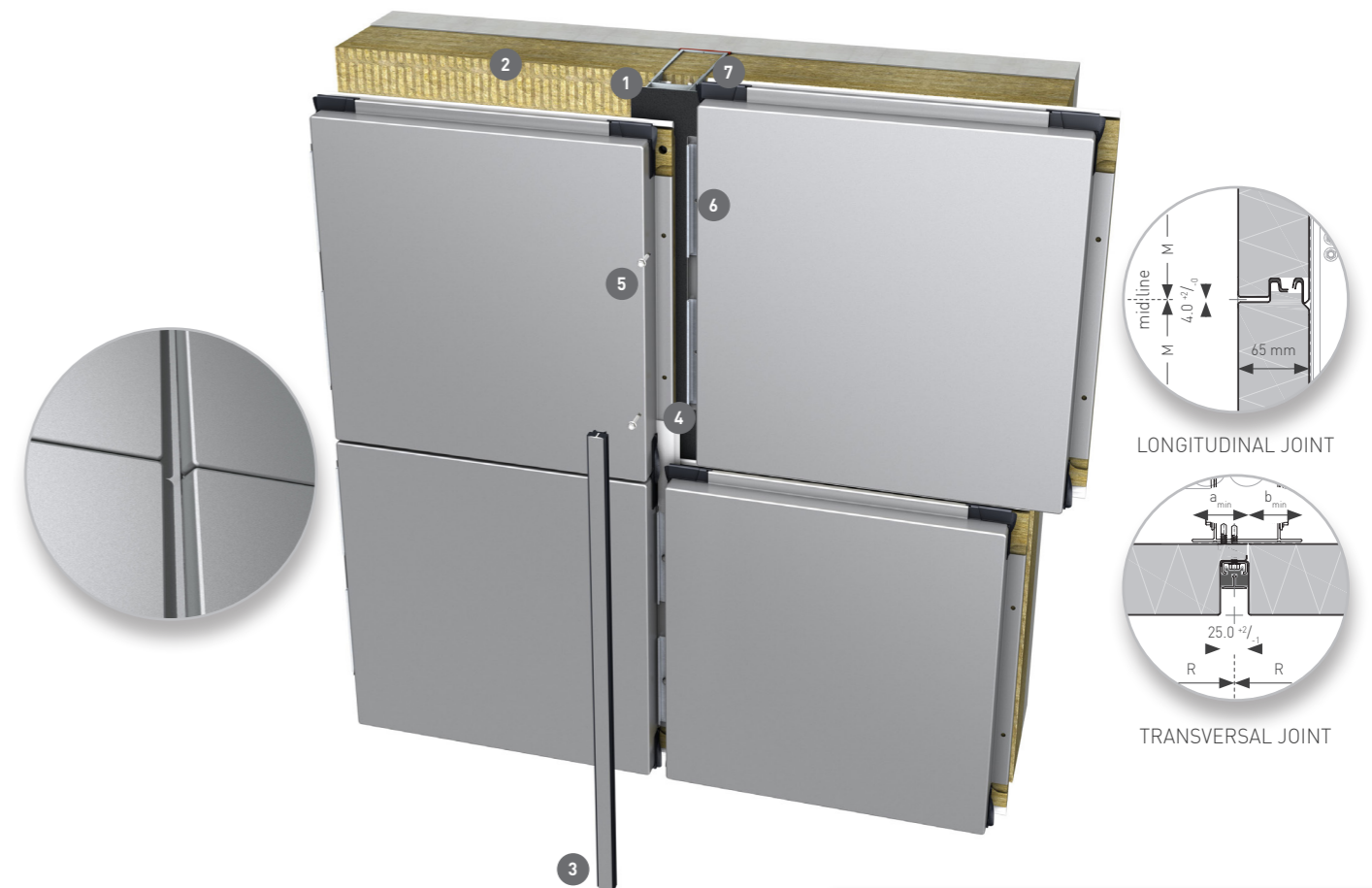

COMPONENTS OF THE SYSTEM

- Modular façade elements
- Fixing and sealing material
- Standard metal sheet flashing
- Joint interface detail for windows and doors
- Corner elements

Minimal width of element support ($a_{min} = b_{min} = 50 \text{ mm}$)

! The dimensions are relevant at the temperature of the element of 10 °C. To ensure the design length [R] of the façade element; the thermal expansion (ΔR) of the Qbiss Screen façade element must be considered during installation.

[🔗 Link to various installation methods chapter](#)

Qbiss Screen MW B-B vertical element joint detail with dimensions.



- 1 Electrochemical potential isolation tape
- 2 Thermal insulation for ventilated façade
- 3 Decorative extrusion and transversal gasket
- 4 Joint profile
- 5 Fixing screw (wind load fixing)
- 6 PE-butyl tape
- 7 Corner gasket

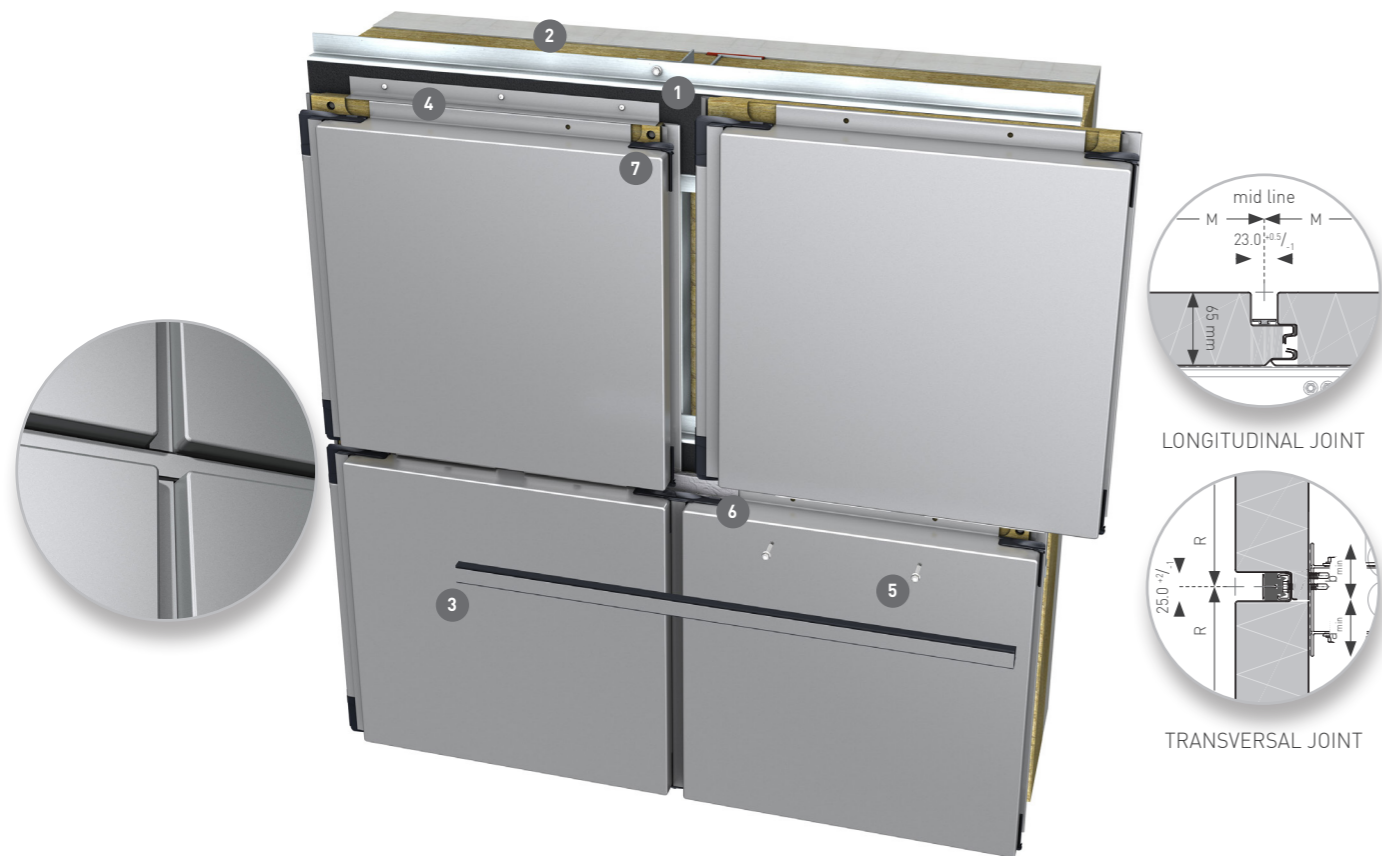

COMPONENTS OF THE SYSTEM

- Modular façade elements
- Fixing and sealing material
- Standard metal sheet flashing
- Joint interface detail for windows and doors
- Corner elements

Minimal width of element support ($a_{min} = b_{min} = 50 \text{ mm}$)

Qbiss Screen H B-B horizontal element joint detail with dimensions.

- 1 Electrochemical potential isolation tape
- 2 Thermal insulation for ventilated façade
- 3 Decorative extrusion and transversal gasket
- 4 Lap joint flanges with stub ends
- 5 Fixing screw (wind load fixing)
- 6 Load bearing fixing plate
- 7 Corner gasket

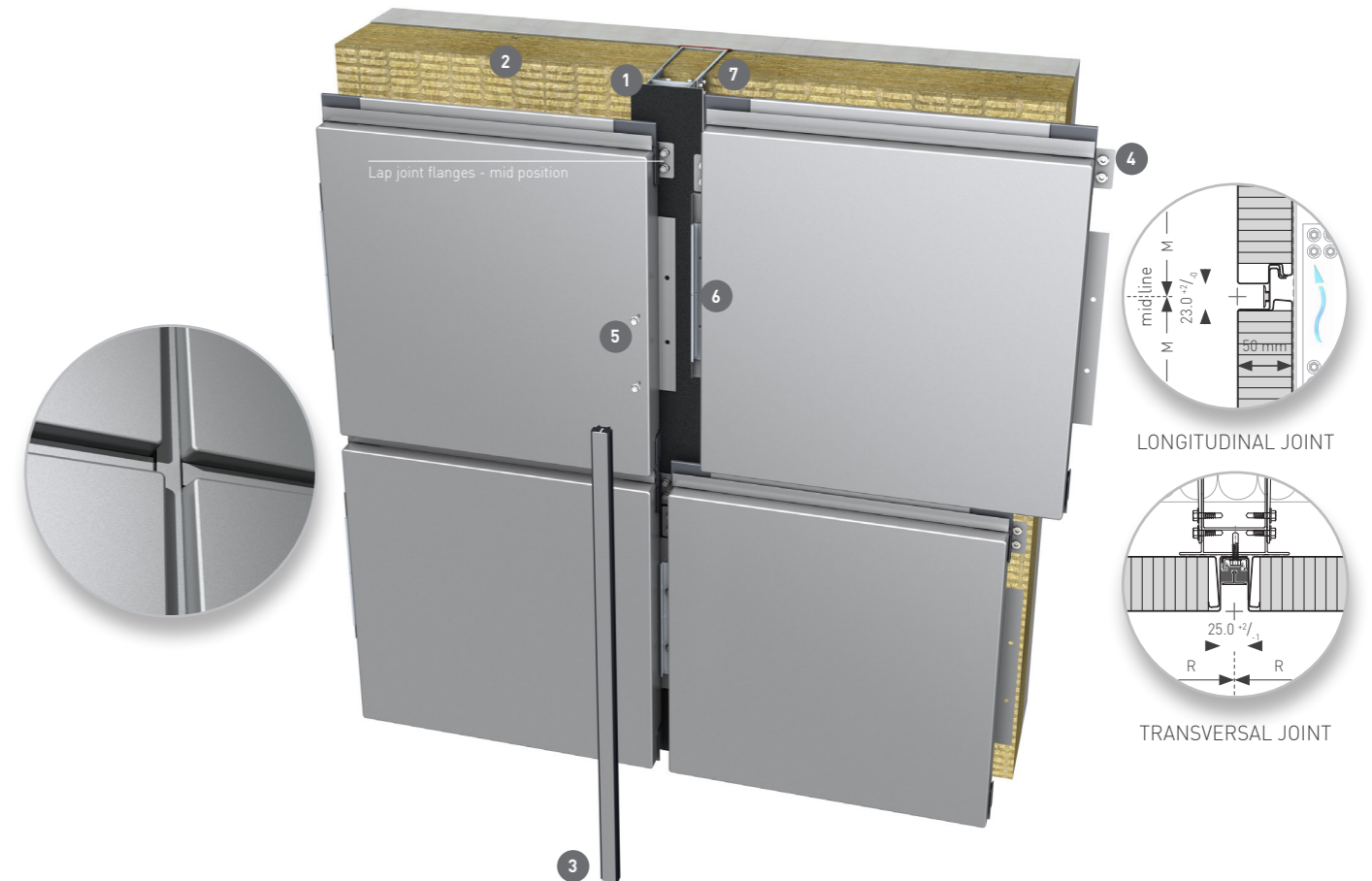

COMPONENTS OF THE SYSTEM

- Modular façade elements
- Fixing (two laps, each side of panel at top of transversal joint) and sealing material
- Standard metal sheet flashing
- Joint interface detail for windows and doors
- Corner elements

Minimal width of element support ($a_{min} = b_{min} = 50 \text{ mm}$)

[Link to various installation methods chapter](#)

Qbiss Screen H F-B horizontal element joint detail with dimensions.

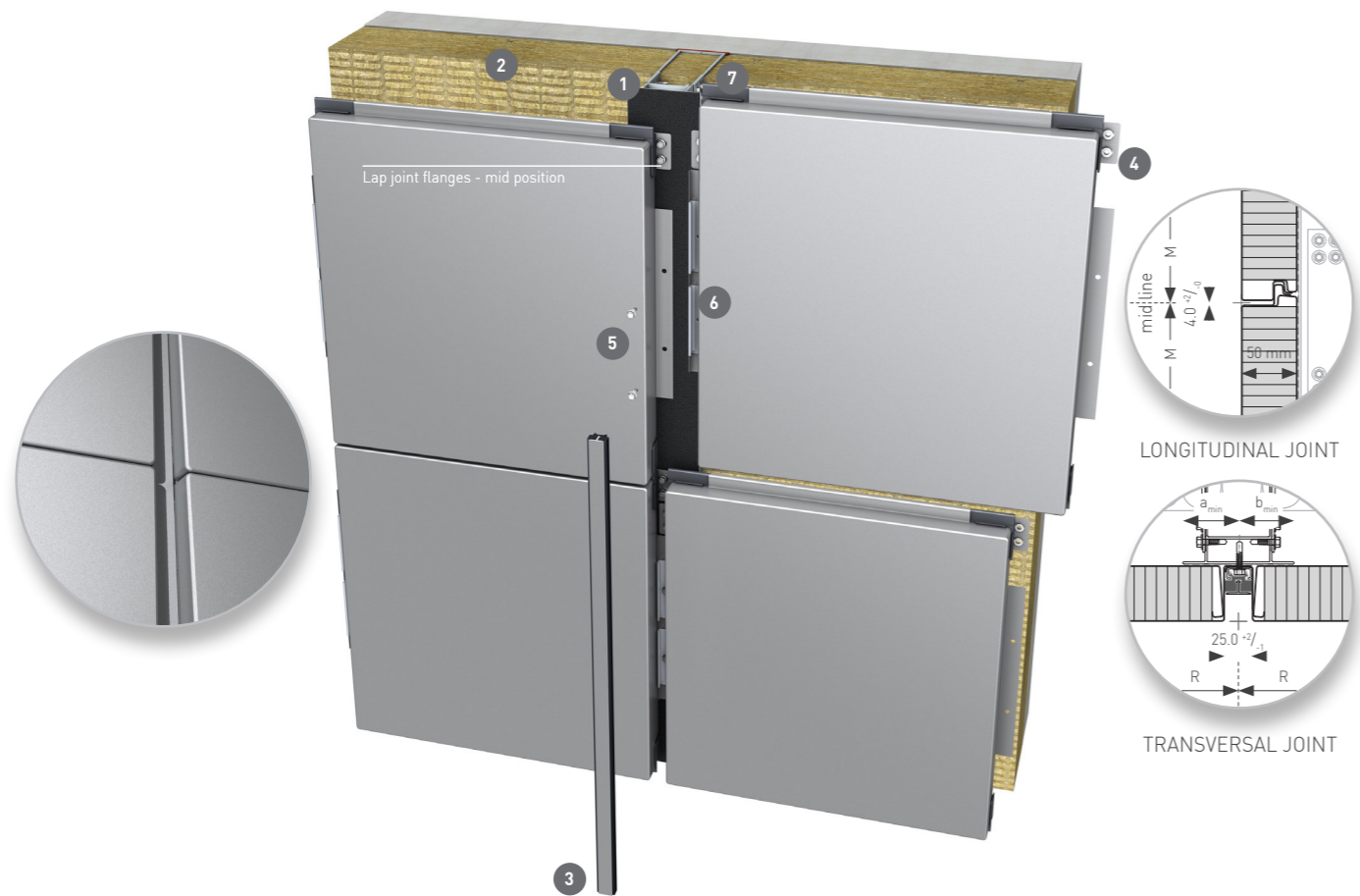

- 1 Electrochemical potential isolation tape
- 2 Thermal insulation for ventilated façade
- 3 Decorative extrusion and transversal gasket
- 4 Lap joint flanges with stub ends
- 5 Fixing screw (wind load fixing)
- 6 Load bearing fixing plate
- 7 Corner gasket

COMPONENTS OF THE SYSTEM

- Modular façade elements
- Fixing (two laps, each side of panel top of transversal joint) and sealing material
- Standard metal sheet flashing
- Joint interface detail for windows and doors
- Corner elements

Minimal width of element support ($a_{min} = b_{min} = 50 \text{ mm}$)

Qbiss Screen H B-B vertical element joint detail with dimensions.

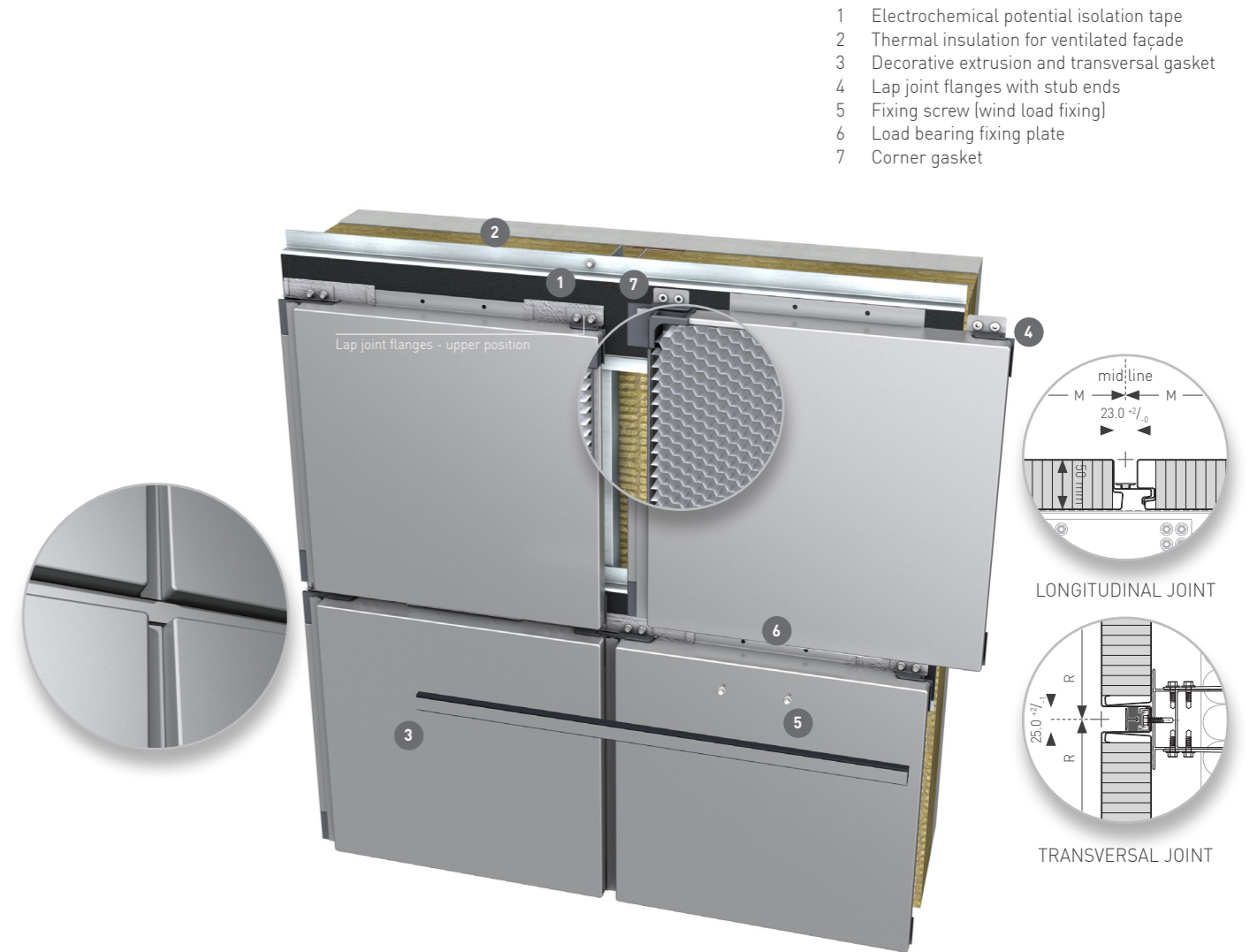

- 1 Electrochemical potential isolation tape
- 2 Thermal insulation for ventilated façade
- 3 Decorative extrusion and transversal gasket
- 4 Lap joint flanges with stub ends
- 5 Fixing screw (wind load fixing)
- 6 Load bearing fixing plate
- 7 Corner gasket

COMPONENTS OF THE SYSTEM

- Modular façade elements
- Fixing (four laps, each corner in transversal joint) and sealing material
- Standard metal sheet flashing
- Joint interface detail for windows and doors
- Corner elements

Minimal width of element support ($a_{min} = b_{min} = 50 \text{ mm}$)

[Link to various installation methods chapter](#)

Qbiss Screen H+ B-B horizontal element joint detail with dimensions.



- 1 Electrochemical potential isolation tape
- 2 Thermal insulation for ventilated façade
- 3 Decorative extrusion and transversal gasket
- 4 Lap joint flanges with stub ends
- 5 Fixing screw (wind load fixing)
- 6 Corner gasket
- 7 Load bearing fixing element HF 63

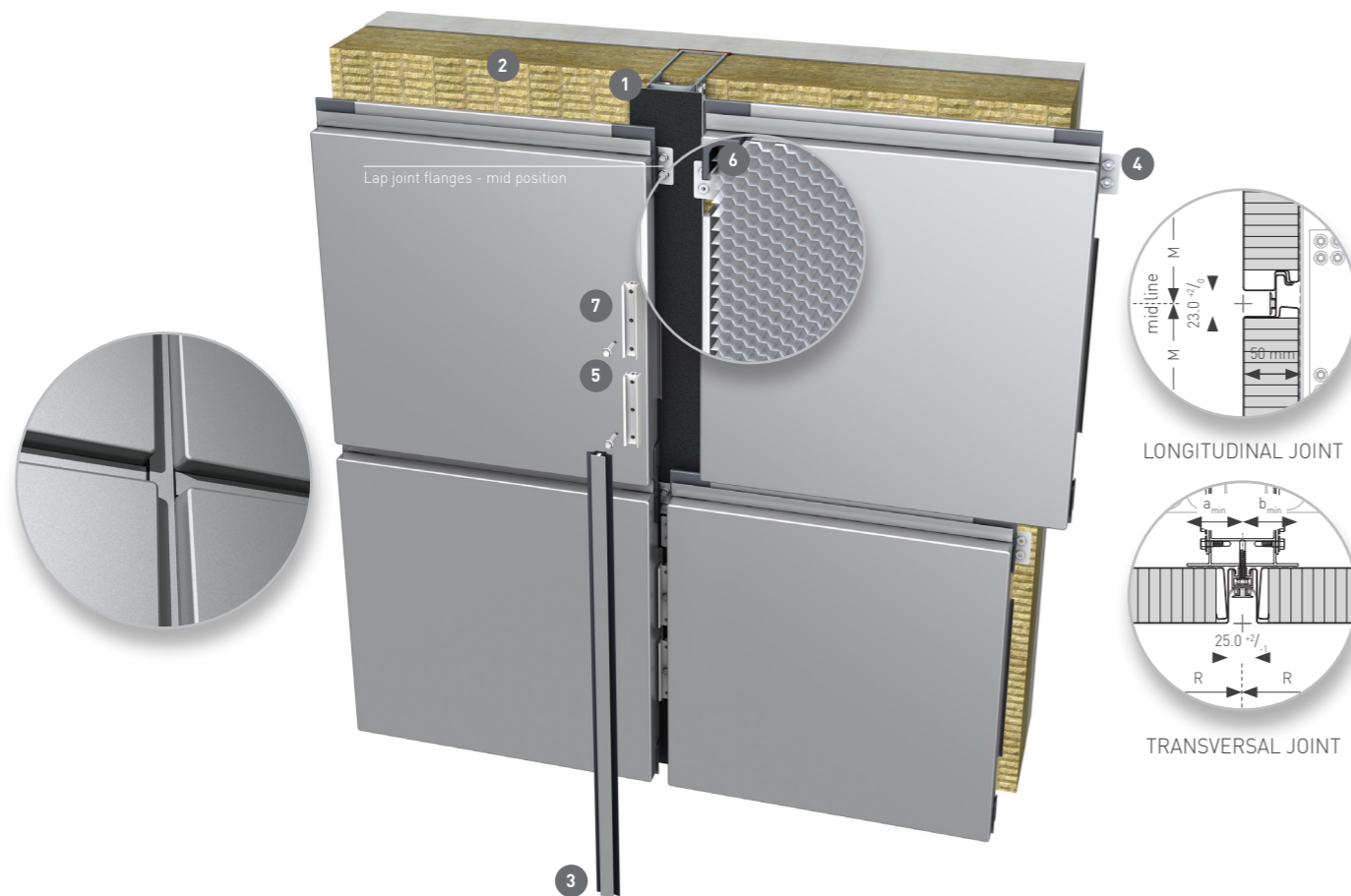

COMPONENTS OF THE SYSTEM

- Modular façade elements
- Fixing and sealing material
- Standard metal sheet flashing
- Joint interface detail for windows and doors
- Corner elements

Minimal width of element support ($a_{min} = b_{min} = 50 \text{ mm}$)

Qbiss Screen H+ F-B horizontal element joint detail with dimensions.

- 1 Electrochemical potential isolation tape
- 2 Thermal insulation for ventilated façade
- 3 Decorative extrusion and transversal gasket
- 4 Lap joint flanges with stub ends
- 5 Fixing screw (wind load fixing)
- 6 Load bearing fixing element HF 63
- 7 Corner gasket

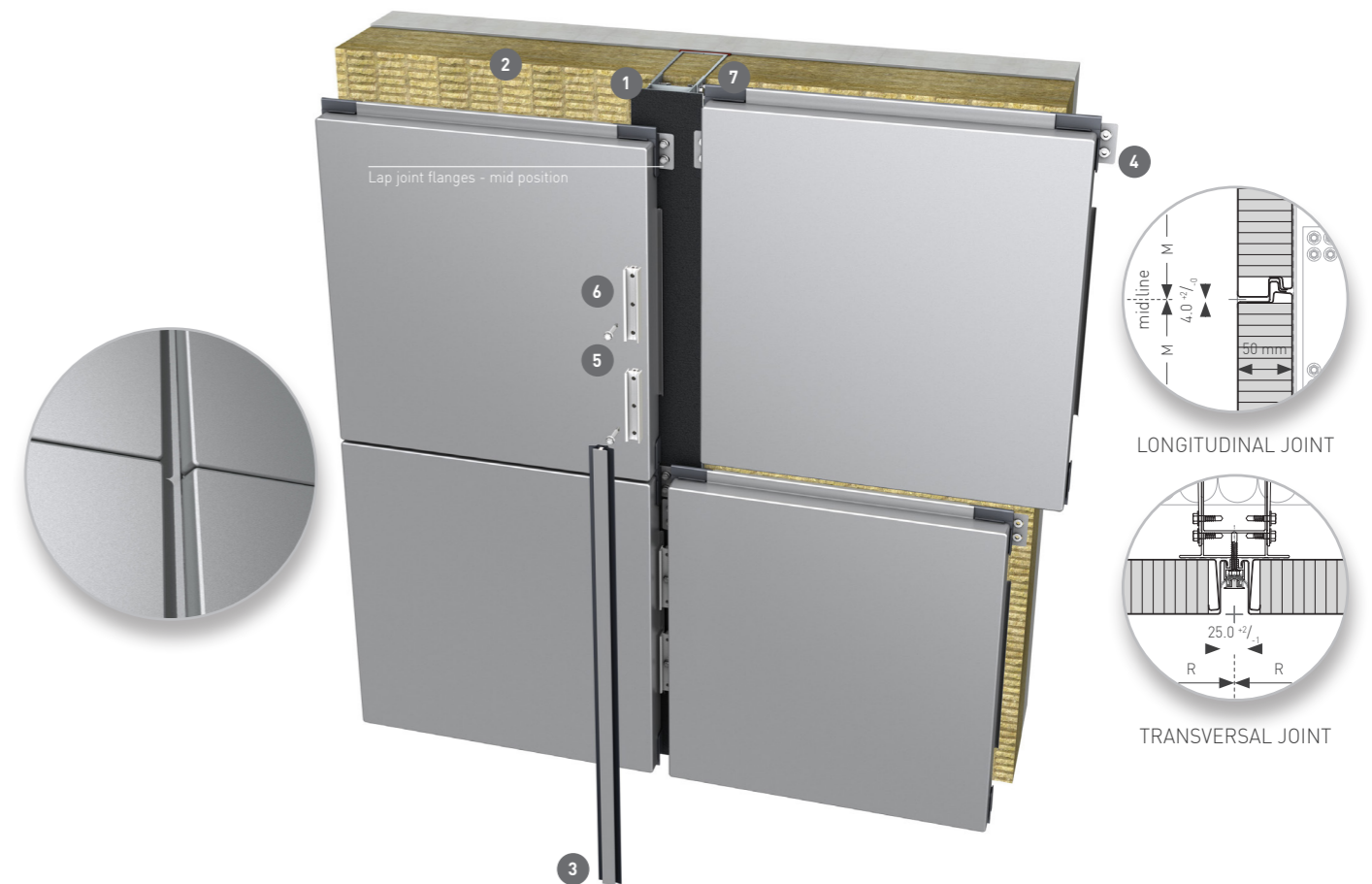

COMPONENTS OF THE SYSTEM

- Modular façade elements
- Fixing and sealing material
- Standard metal sheet flashing
- Joint interface detail for windows and doors
- Corner elements

Minimal width of element support ($a_{min} = b_{min} = 50 \text{ mm}$)

[Link to various installation methods chapter](#)

Qbiss Screen H+ B-B vertical element joint detail with dimensions.

 closed element corners

- 1 Electrochemical potential isolation tape
- 2 Thermal insulation for ventilated façade
- 3 Decorative extrusion and transversal gasket
- 4 Lap joint flanges with stub ends
- 5 Fixing screw (wind load fixing)
- 6 Load bearing fixing element HF 63
- 7 PE-butyl tape
- 8 Corner gasket

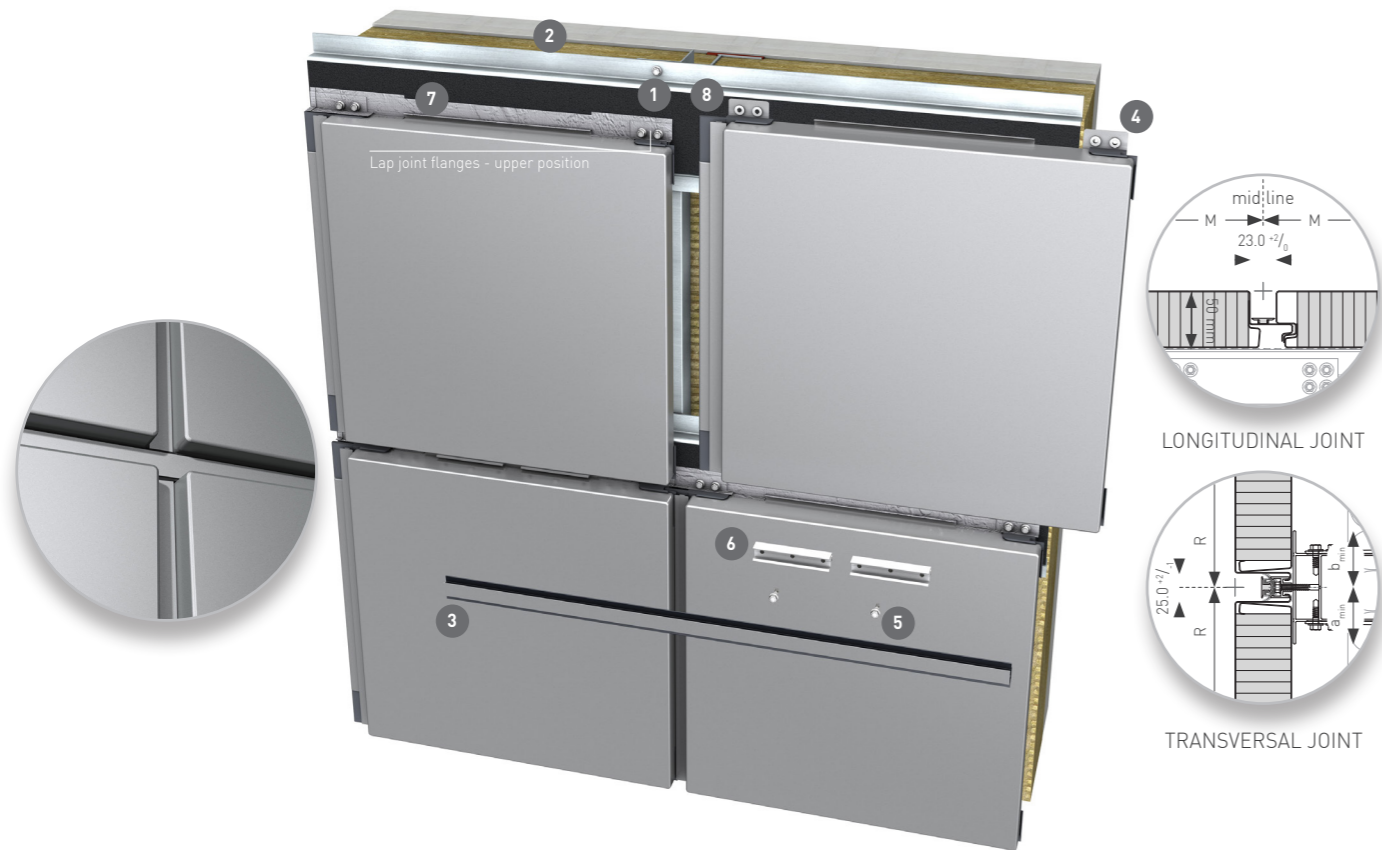

COMPONENTS OF THE SYSTEM

- Modular façade elements
- Fixing and sealing material
- Standard metal sheet flashing
- Joint interface detail for windows and doors
- Corner elements

Minimal width of element support ($a_{min} = b_{min} = 50 \text{ mm}$)

! Qbiss Screen H+ vertical element is allowed to be used as an internal wall application only.

OVERVIEW OF QBISS SCREEN COMPOSITION TYPES

APPLICATION / PROPERTIES	MW	H	H+	DESCRIPTION
BIM libraries availability	•	•	••••	Available for ARCHICAD and Revit software. See page 135
Standard details availability	••••	••••	••••	Qbiss Screen MW, H and H+ system design details available.
Ventilated façade (H installation)	••••	•••	•••	Check installation methods. See page 74
Ventilated façade (V installation)	••••	•••	••	Check installation methods. See page 75
Internal wall	•••	•••	•••	See page 70
Brick in longitudinal joint	•	•••	•••	See page 74
Brick in transversal joint	•••	-	-	See page 75
Trapezoidal element	••••	-	-	-
Ceiling element	•••	••••	-	-
Corner element (visual effect)	••••	•	•	-
Reaction to fire (A2)	••••	••••	••••	See page 36
Manufacturing (tolerances)	••••	•••	•••	-
Artme application	••••	-	-	See page 56
Replacement of the element	•••	•••	••••	See page 126
Qbiss One connectivity	••••	••••	•	Can be used together with Qbiss One façade cladding.

- Suitable without reservations
- Suitable
- Suitable for interior applications only
- Contact Trimo for consultancy
- Unsuitable

INSTALLATION METHODS

INSTALLATION DIRECTION

Qbiss Screen elements can be distinguished based on installation methods and direction of installation. Elements laid together in horizontal and vertical direction are not compatible with each other.

Qbiss Screen H B-B horizontally and vertically laid element

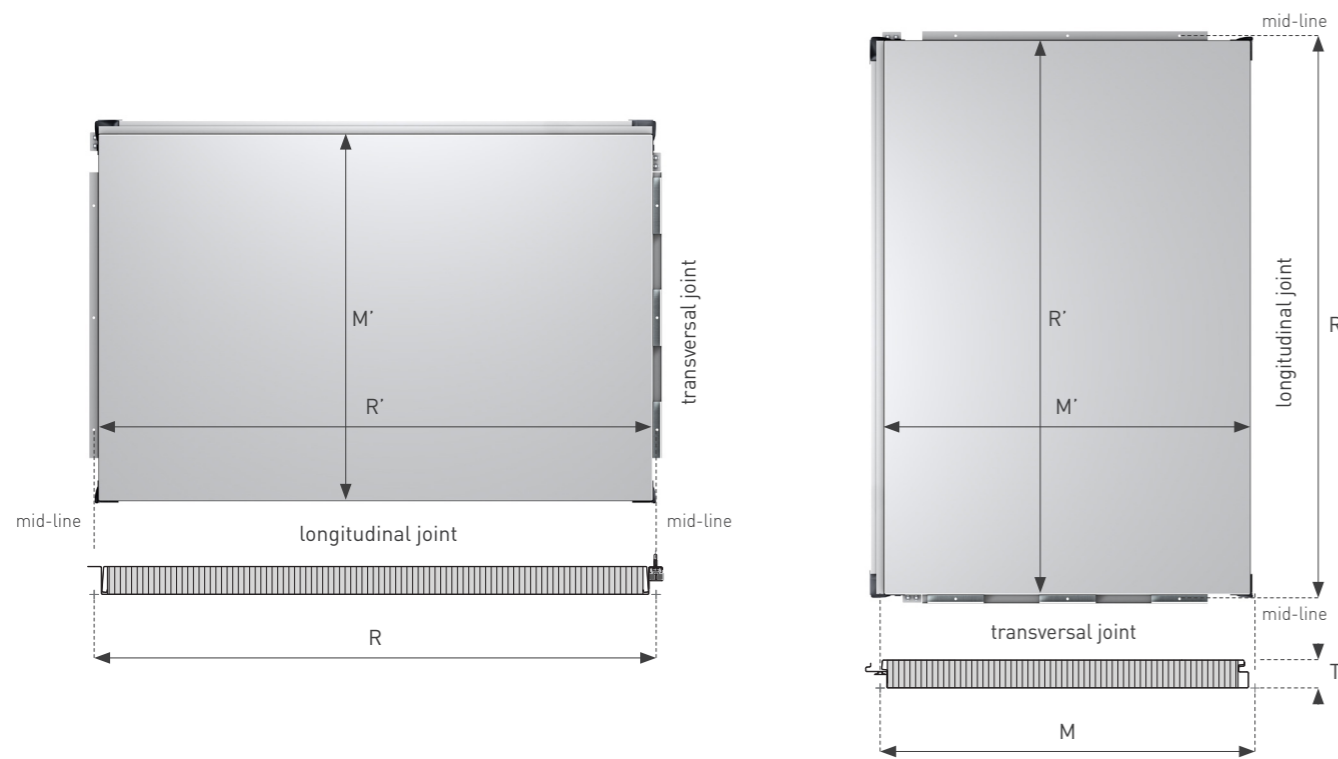

Correct orientation of horizontal installation must be ensured to allow the water to drain (the tongue on the longitudinal joint must always face upwards).

Correct orientation of vertical installation ensures the longitudinal thermal expansion. The laps of the element help positioning the self-weight fixings.



- R – Design length
- R' – Qbiss Screen element face length
- M – Module width
- M' – Qbiss Screen element face width
- T – Qbiss Screen element thickness

PHYSIO AUGSBURG
GERMANY

HORIZONTAL QBISS SCREEN H

2018

SCHULZE + PARTNER ARCHITEKTEN

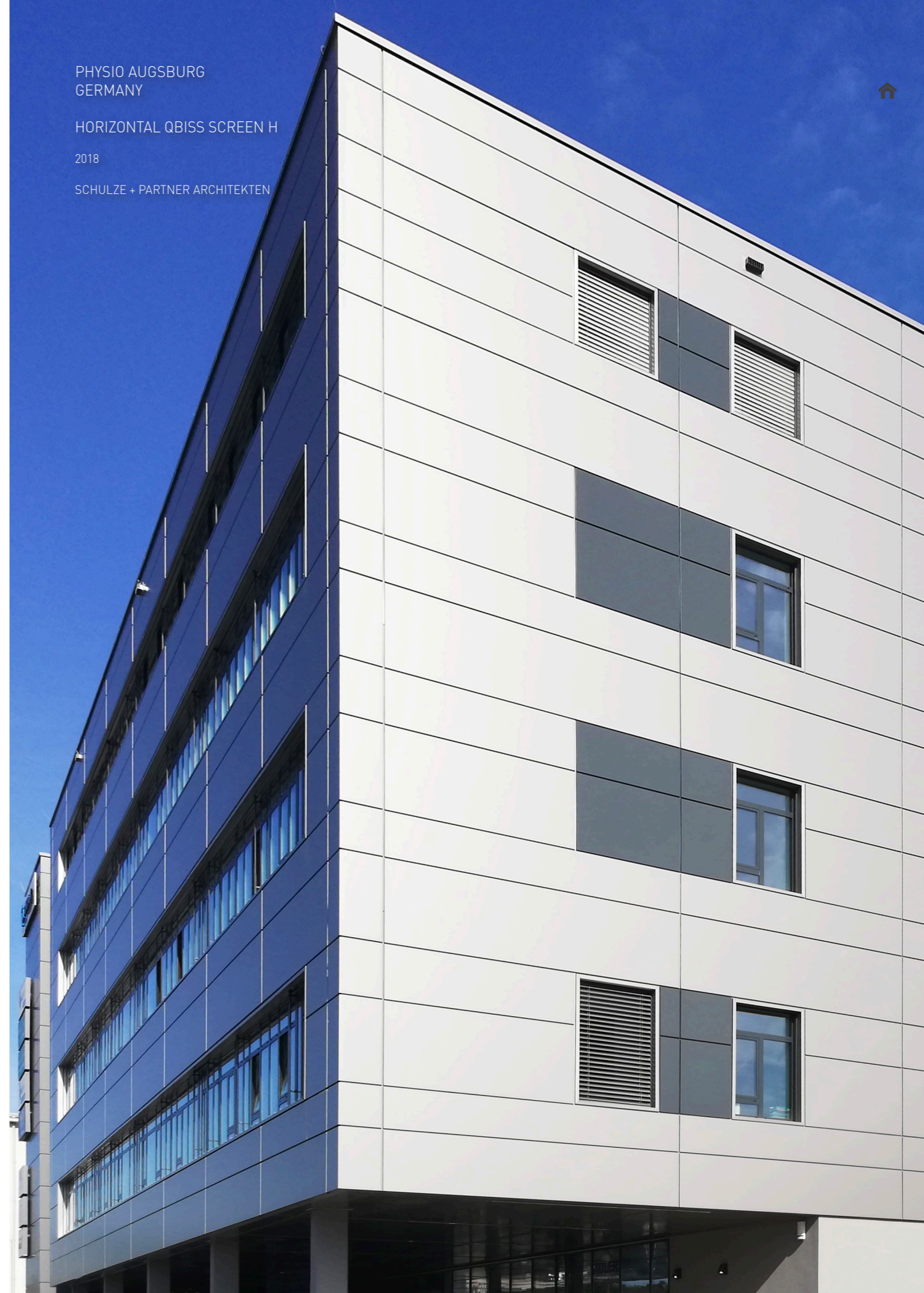



INSTALLATION RECOMMENDATIONS

The installation is preferably initiated using a Qbiss Screen corner element at the outer boundary axis of the building. Alternatively, installation can start with the first adjacent Qbiss Screen façade element and the bottom row.

Regardless of installation direction, the first row on the main beam should be constructed, and all the other rows should be installed as “pyramidal” system (see the schemes below).

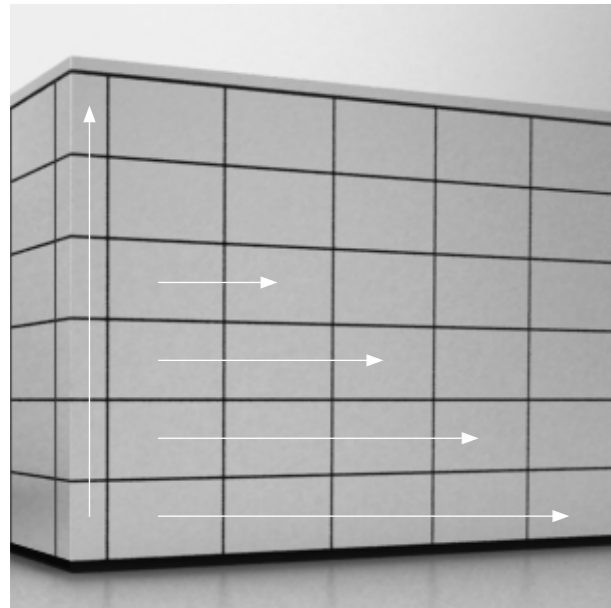

Horizontal installation direction from left to right.

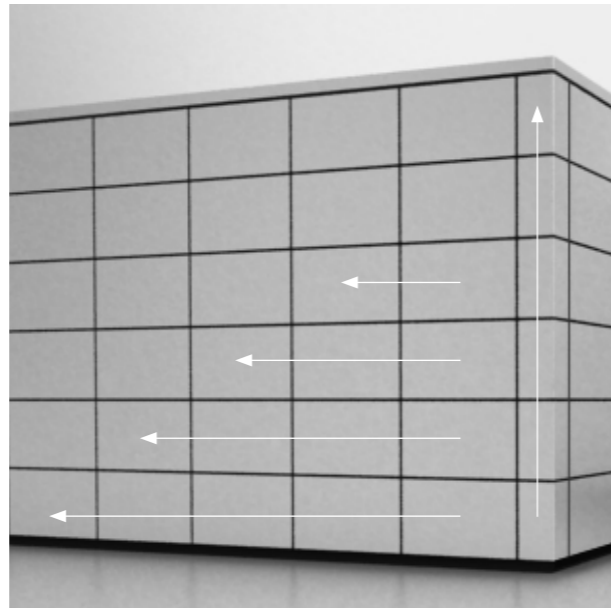

Horizontal installation direction from right to left.

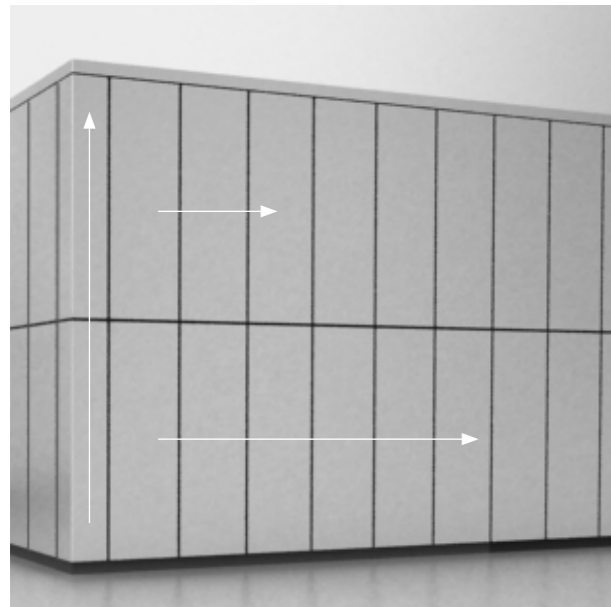

Vertical installation direction from left to right.

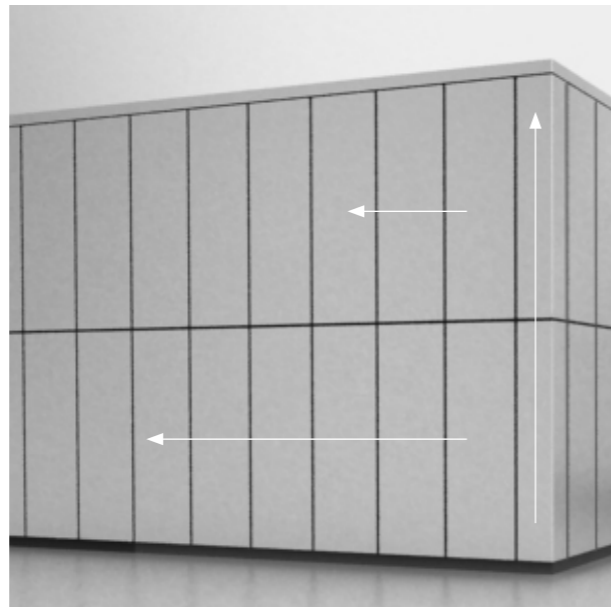

Vertical installation direction from right to left.

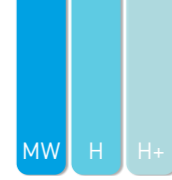

Qbiss Screen element types

Element type	Element finishing scheme	Element format	Installation direction	Installation method
1	QSMW, QSHA	BOTH - SIDED	LEFT - RIGHT	HORIZONTAL, VERTICAL, HORIZONTAL BRICK (QSH), HORIZONTAL ASYMMETRICAL BRICK (QSH), VERTICAL BRICK (QSMW)
2	QSMW, QSHA	BOTH - SIDED	RIGHT - LEFT	HORIZONTAL, HORIZONTAL BRICK (QSH), HORIZONTAL ASYMMETRICAL BRICK (QSH)
3	QSMW, QSHA	BOTH - SIDED	INITIAL (FIRST)	HORIZONTAL, VERTICAL, HORIZONTAL BRICK (QSH), HORIZONTAL ASYMMETRICAL BRICK (QSH), VERTICAL BRICK (QSMW)
4	QSMW, QSHA	BOTH - SIDED	TERMINAL (LAST)	HORIZONTAL, HORIZONTAL BRICK (QSH), HORIZONTAL ASYMMETRICAL BRICK (QSH)
5	QSMW, QSH	RIGHT	INITIAL (FIRST)	HORIZONTAL, VERTICAL, HORIZONTAL BRICK (QSH), HORIZONTAL ASYMMETRICAL BRICK (QSH), VERTICAL BRICK (QSMW)
6	QSMW, QSHA	RIGHT	TERMINAL (LAST)	HORIZONTAL, HORIZONTAL BRICK, HORIZONTAL ASYMMETRICAL BRICK
7	QSMW, QSHA	LEFT	INITIAL (FIRST)	HORIZONTAL, VERTICAL, HORIZONTAL BRICK (QSH), HORIZONTAL ASYMMETRICAL BRICK, VERTICAL BRICK (QSMW)
8	QSMW, QSHA	LEFT	TERMINAL (LAST)	HORIZONTAL, VERTICAL, HORIZONTAL BRICK, HORIZONTAL ASYMMETRICAL BRICK (QSH), VERTICAL BRICK (QSMW)
9	QSMW, QSHA	NONE	INITIAL (FIRST) TERMINAL (LAST) LEFT - RIGHT RIGHT - LEFT	HORIZONTAL, VERTICAL, HORIZONTAL BRICK (QSH), HORIZONTAL ASYMMETRICAL BRICK (QSH), VERTICAL BRICK (QSMW)
13	QSH+A	BOTH - SIDED	LEFT - RIGHT RIGHT - LEFT	HORIZONTAL, VERTICAL (only as internal wall), HORIZONTAL BRICK, HORIZONTAL ASYMMETRICAL BRICK, VERTICAL BRICK (only as internal wall)

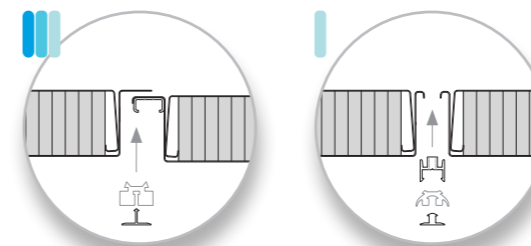

Qbiss Screen MW, H and H+ element type 2 joint marriage

! In case of Qbiss Screen brick installation, the amount of substructure increases.

VARIOUS INSTALLATION METHODS

To give architects the possibility to express their style by choosing Qbiss Screen façade elements / system, we developed elements, that can be installed in various possible ways.

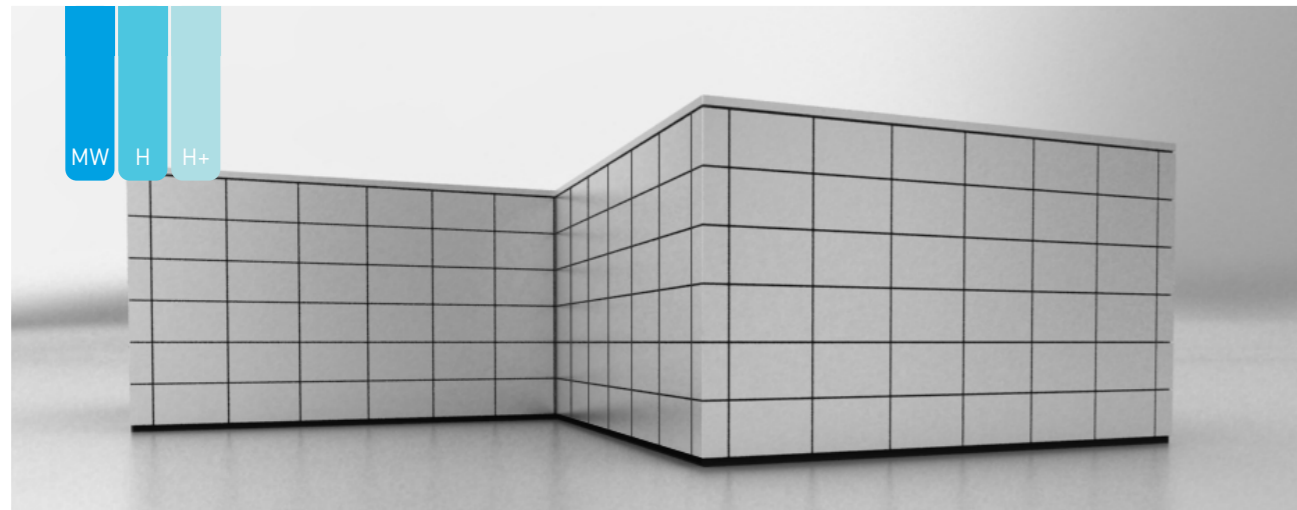

HORIZONTAL INSTALLATION

Horizontal façade system consists of individual façade elements which are joined together and linked in a horizontal direction using a tongue and groove system and attached vertically to the load-bearing structure. Transversal joints are sealed with a specially profiled gasket.

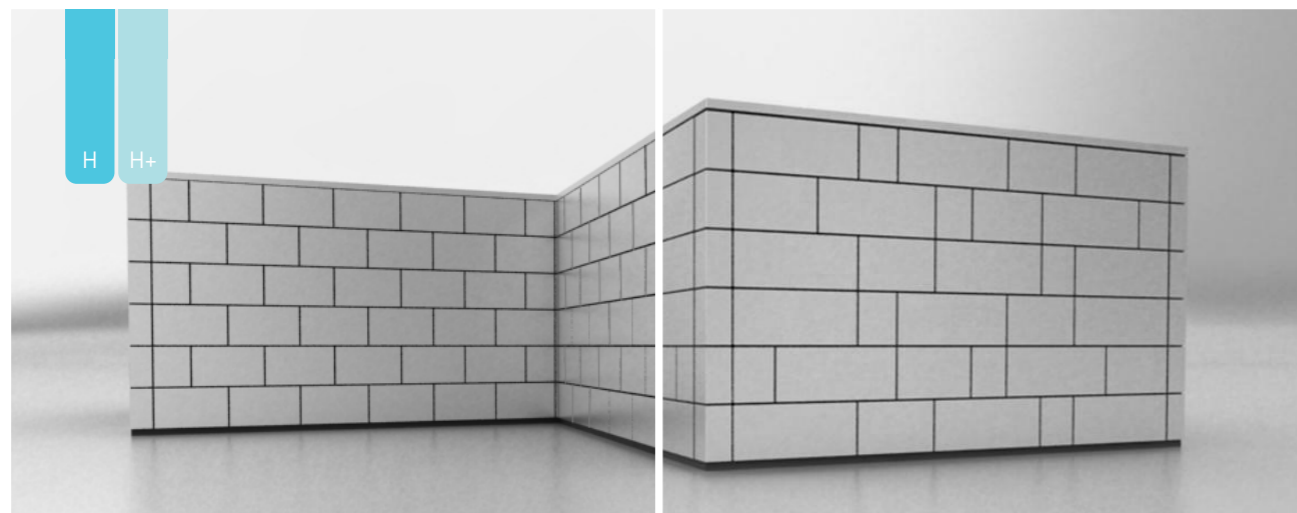

HORIZONTAL BRICK AND ASYMMETRICAL HORIZONTAL BRICK INSTALLATION

Horizontal installation by shifting or so-called "Brick Installation" enables the shift (shifting of the vertical joint in the middle of the upper or lower façade element) but also means that the vertical joints can be positioned anywhere on the longitudinal axis of neighbouring horizontal façade elements. Qbiss Screen façade elements for horizontal brick installation method are special – elements are not interchangeable with Qbiss Screen façade elements for installation with alignment joints.

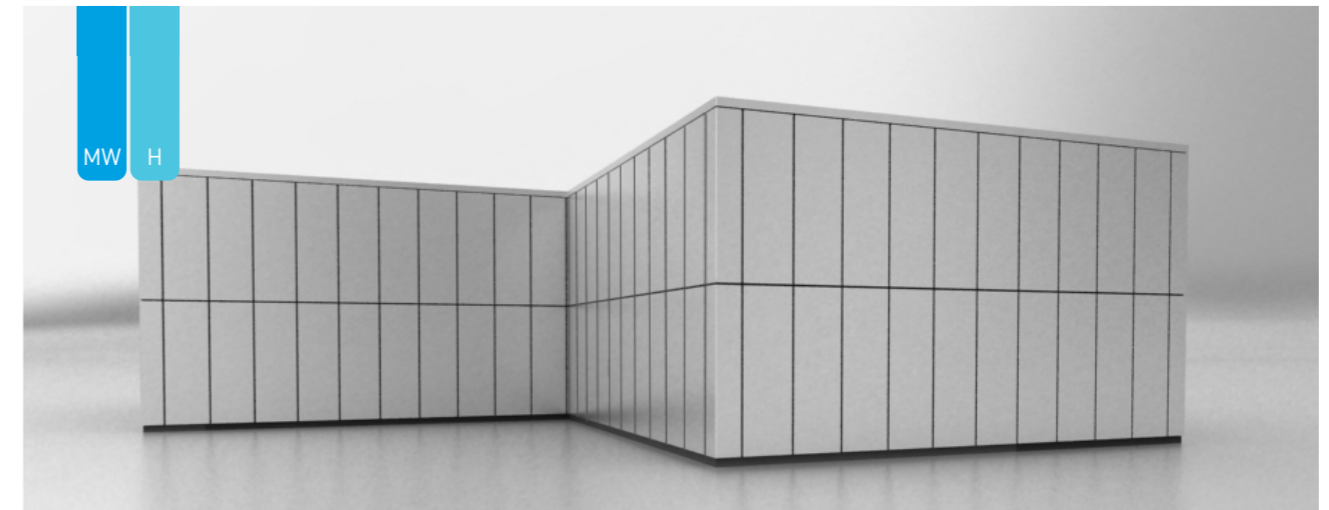

VERTICAL INSTALLATION

Vertical installation system is composed of individual façade elements, joined in a vertical direction (longitudinal joint) with a tongue - groove system and affixed to the supporting structure in a horizontal direction.

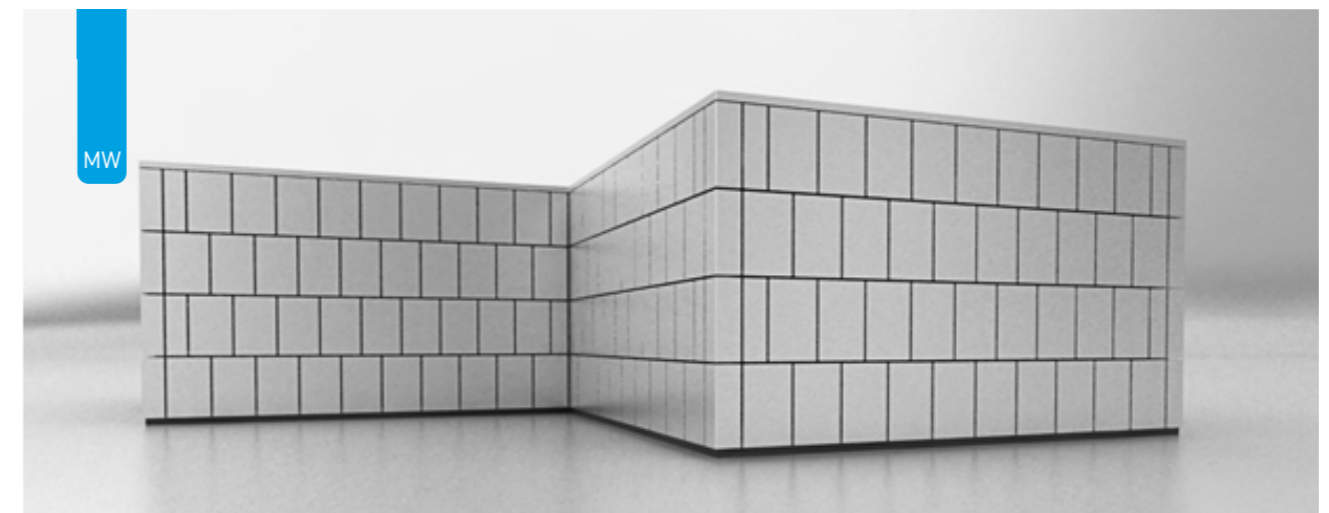

VERTICAL BRICK INSTALLATION

Qbiss Screen façade elements for this installation method are special – elements are not interchangeable with Qbiss Screen façade elements for installation with alignment joints.

! Qbiss Screen H+ vertical element is allowed to be used as an internal wall application only.

JOINT OPTIONS

ELEMENT VARIATIONS

Qbiss Screen allows various combinations of recessed and flushed joints. It presents the ultimate combination of aesthetics, design and functionality. A playground for architects and a tool to show the world the excellence of design.

Qbiss Screen rainscreen is a system with a shadow line joint. Longitudinal and transversal frame-struts are joined to hold the complete rainscreen elements in place, enable modular construction and easy composition of desired façade designs.

The system is based on Qbiss Screen B-B modular façade element. It allows you to use different types of joints between elements. Discover all possibilities:

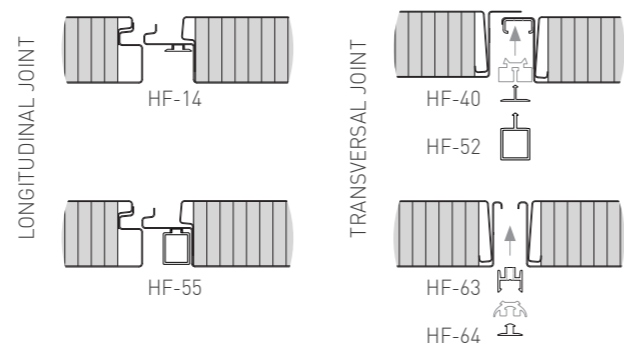

QBISS SCREEN VERTICAL ELEMENT JOINT OPTIONS

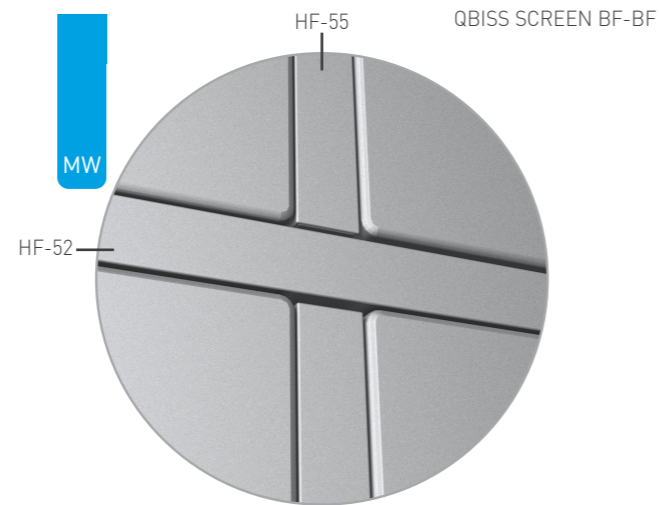
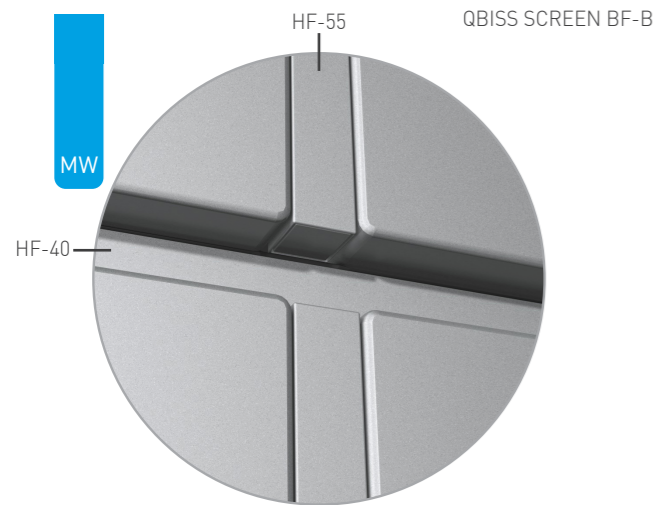
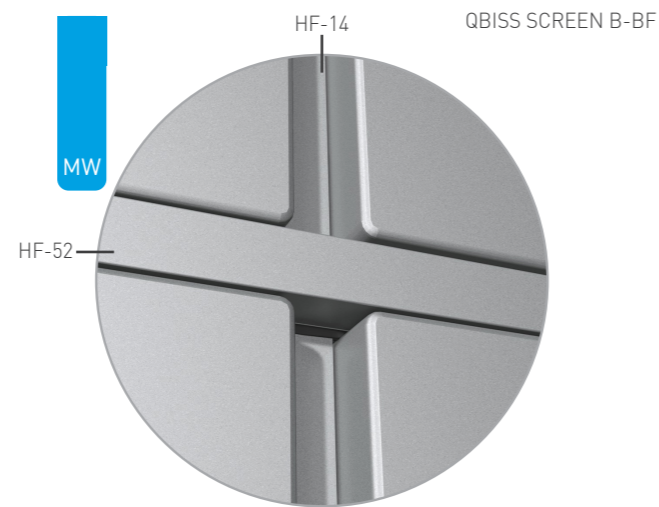
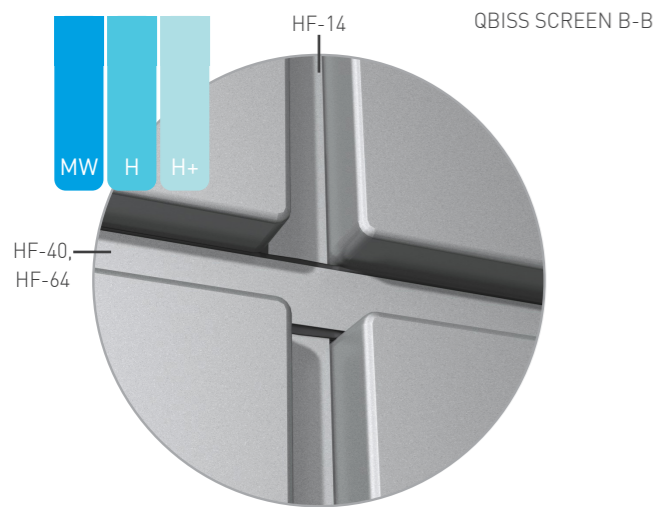

QBISS SCREEN HORIZONTAL ELEMENT JOINT OPTIONS

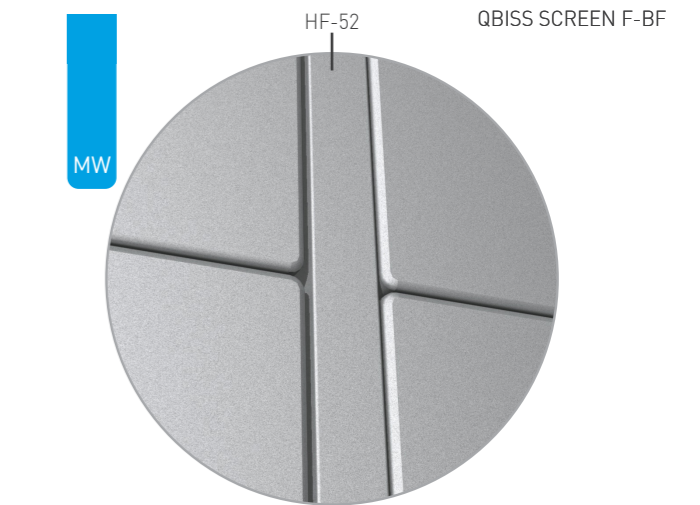
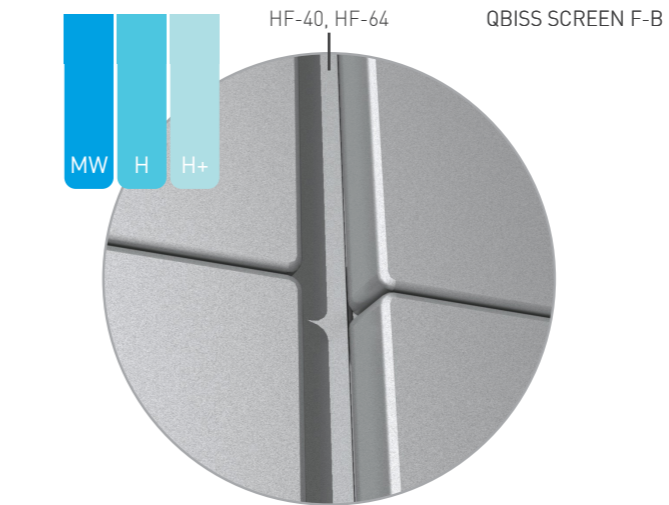
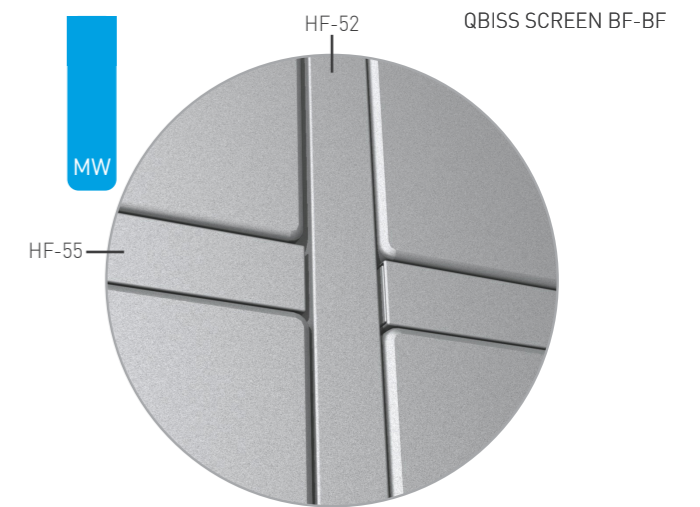
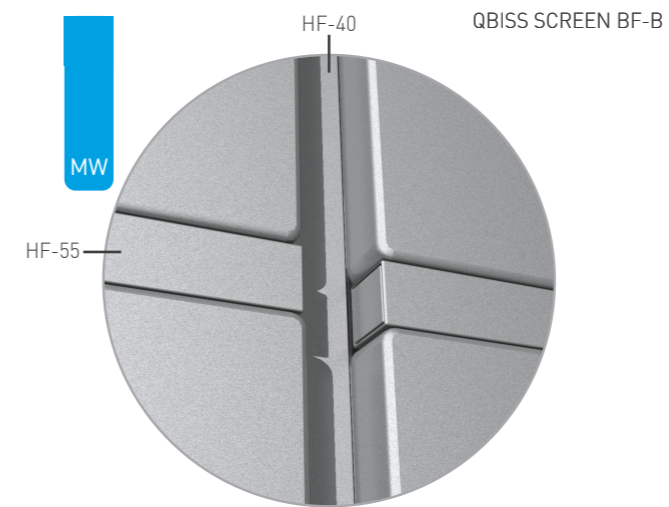
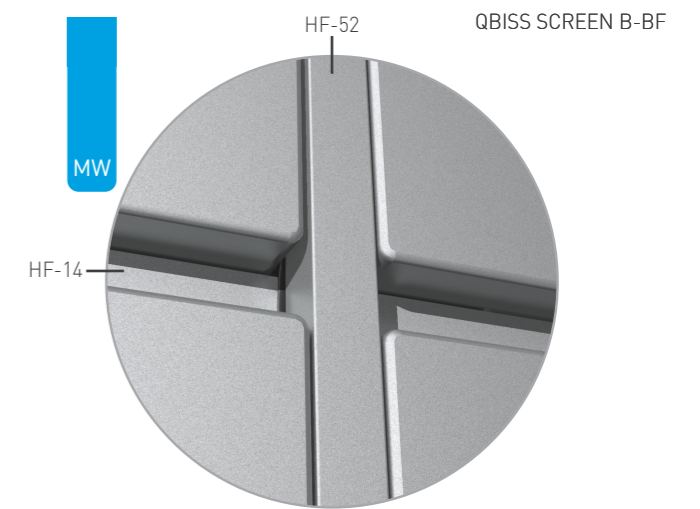
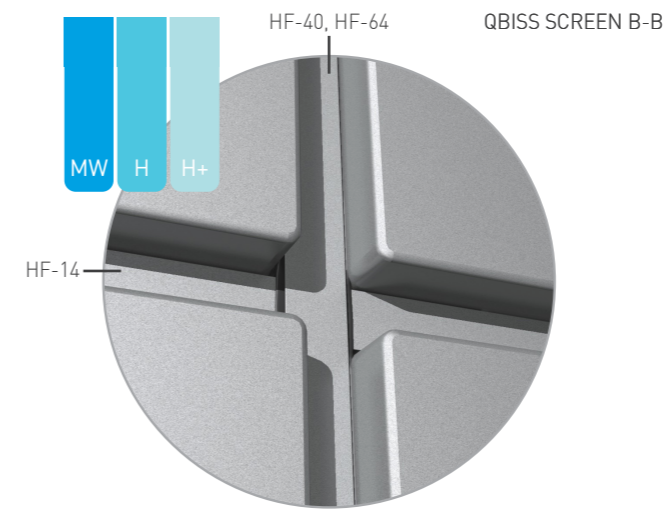

SELECTION OF FIXINGS & METHODS

SELECTION OF FIXINGS ACCORDING TO DESIGN REQUIREMENTS

The Qbiss Screen façade elements are fixed to façade structure or sub-structure through the internal and external steel skin. The Qbiss Screen façade element has pre-punched fixing holes at the fixing points. The required number of screws is defined by project's structural calculation. The type of screw depends on the material of the substructure.

GENERAL FIXING MATERIAL FOR QBISS SCREEN MW

Material	S min (mm)	B min (mm)	Screw type	ETA
Aluminium	up to 5,0 mm	65	Ejot JT3 6-5.5-50 (A2)	ETA-10/0200
Steel	up to 5,0 mm	65	Ejot JT3 6-5.5-50 (A2)	ETA-10/0200
	more than 5,0 mm	65	Ejot JT3 12-5.5-58 (A2)	ETA-10/0200
Stainless steel		65	Ejot JT3 6-5.5-50 (A2)	-

Qbiss Screen MW fixing material for self-weight load fixing.

Material	S min (mm)	Screw type	ETA
Aluminium	3,00	Ejot JT4 6-5.5-30 (A2)	ETA-10/0200
Aluminium	2,00	Ejot JT9 6-5.5-30 (A4)	ETA-10/0200
Steel	up to 5,0 mm	E-VS BOHR 3 5,5 X 25	-
	5 mm - 12,5 mm	E-VS BOHR 5 5,5 X 32	-
Stainless steel	up to 5,0 mm	E-VS BOHR 3 5,5 X 25	-
	5 mm - 12,5 mm	E-VS BOHR 5 5,5 X 32	-

Qbiss Screen MW fixing material for transversal joint (wind load).

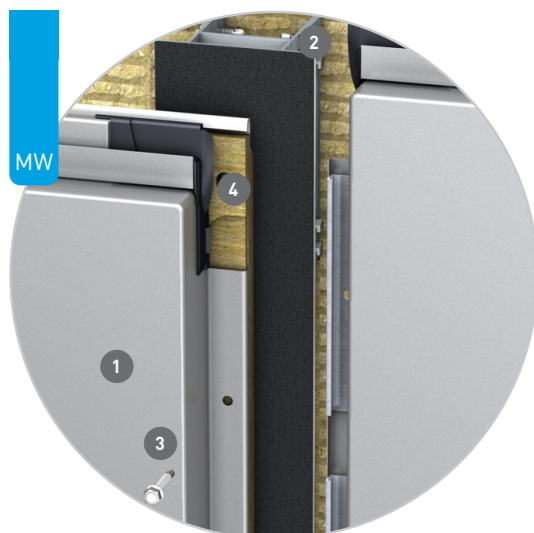

Fixing element through back side steel skin-lap joint

- 1 Qbiss Screen MW element
- 2 Aluminium substructure – load bearing profile
- 3 Fixing screw (wind load)
- 4 Fixing screw (self-weight load fixing)

S – Thickness of substructure
ETA – European Technical Assessment

GENERAL FIXING MATERIAL FOR QBISS SCREEN H AND H+

Material	S min (mm)	B min (mm)	Screw type	ETA
Aluminium	3,00	50	Ejot JT4 6-5.5-30 (A2)	ETA-10/0200
	2,00	50	Ejot JT9 6-5.5-30 (A4)	ETA-10/0200
Steel	2,00	50	Ejot JT3 6-5.5-25 (A2)	ETA-10/0200
	2,00	50	Ejot JT6 6-5.5-35 (A4)	ETA-10/0200
	2,00	50	SFS SX5 - 5.5-35 (A2)	ETA-10/0198
	2,00	50	SFS SX5 - 5.5-35 (A4)	ETA-10/0198
Stainless steel	2,00	50	Ejot JT3 6-5.5-25 (A2)	-
	2,00	50	Ejot JT6 6-5.5-35 (A4)	-

Qbiss Screen H and Qbiss Screen H+ fixing material for self-weight load fixing.

Material	S min (mm)	Screw type	ETA
Aluminium	3,00	Ejot JT4 6-5.5-22 (A2)	ETA-10/0200
	2,00	Ejot JT9 6-5.5-22 (A4)	ETA-10/0200
Steel	2,00	Ejot JT3 6-5.5-22 (A2)	ETA-10/0200
Stainless steel	2,00	Ejot JT3 6-5.5-35 (A2)	ETA-10/0200
	2,00	Ejot JT6 6-5.5-35 (A4)	ETA-10/0200

Qbiss Screen H and Qbiss Screen H+ fixing material for transversal joint (wind load).

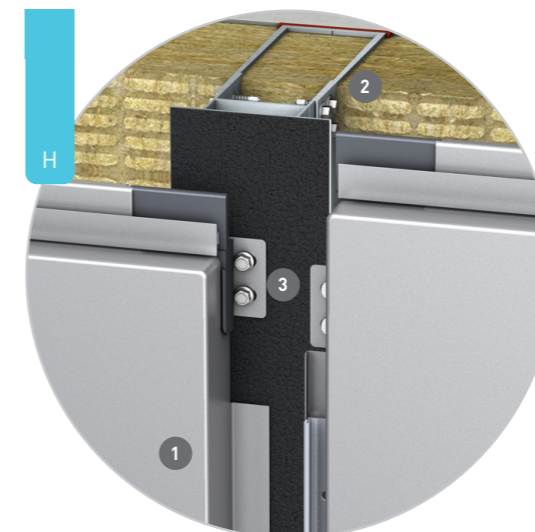

Fixing element through back side steel skin-lap joint

- 1 Qbiss Screen element
- 2 Aluminium substructure – load bearing profile
- 3 Screw for lap joint fixing

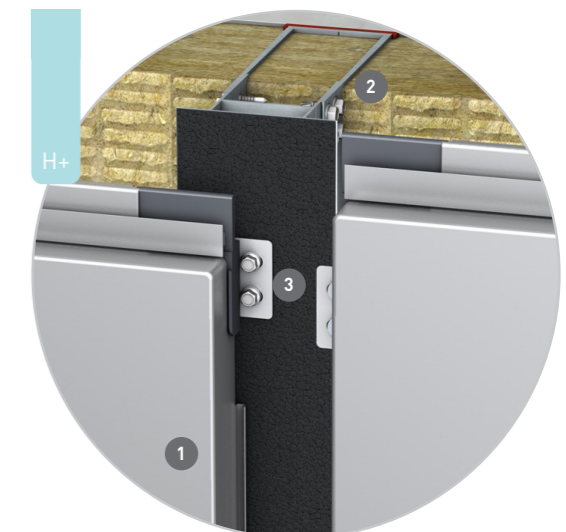

Structural calculation for element fixing must be performed prior installation. Please contact Trimo technical support.

QBISS SCREEN ELEMENT FIXING

Installation sequence follows positioning, fixing and installation of sealing elements. To ensure constant space between two elements, during installation, centering cross is to be used.

After Qbiss Screen element is positioned by using the installation centering cross, the element is fixed with two screws on each side through laps (vertical load fixation). Aluminium fixing element must be positioned in the center of the joint to allow enough gap for thermal expansion of the elements. Installation cross-spacer allows a proper load bearing fixing element (HF 63) positioning.

Required distance between fixings, depends on element module width (M). Distribution of fixing elements and screws is the same for horizontal and vertical installation.

Installation sequence:

- 1 Fixing element HF 63 is inserted into the cross-spacer.
- 2 Placing fixing element with cross spacer into the groove.
- 3 Fixing the HF 63 element with the wind load screw.
- 4 Removing the installation cross-spacer.

After all fixing elements are mounted, transversal gasket with a decorative extrusion is inserted into transversal joint. The sequence applies to horizontal and vertical installation.

- 1 Installation cross-spacer
- 2 Fixing screw (wind load)
- 3 Decorative extrusion and transversal gasket
- 4 Lap joint flanges with stub ends
- 5 Fixing screw (self-weight load fixing)
- 6 Load bearing fixing element HF 63
- 7 Installation centering cross B-B

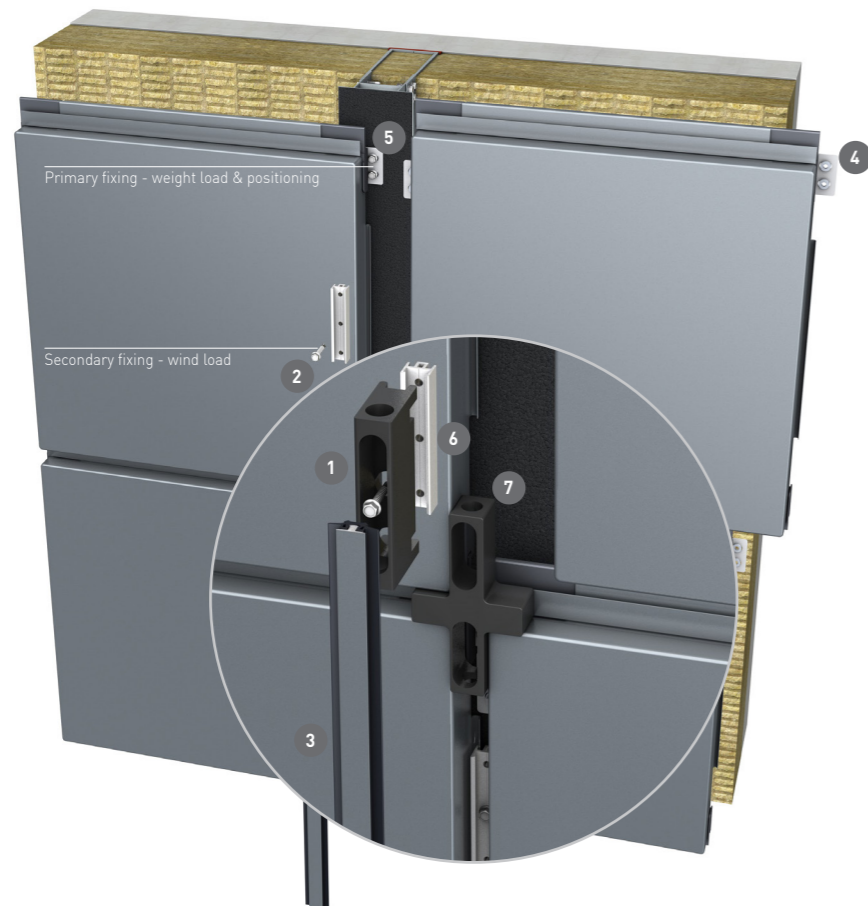

MTD BIO KOMATSU, HANNOVER
GERMANY

HORIZONTAL AND VERTICAL
QBISS SCREEN MW

2019

htm.a HARTMANN ARCHITEKTUR



Elements are fixed to a steel structure by use of integrated fixing plate with screws. Required distance between fixings, depends on element module width (M). Distribution of fixing elements and screws is the same for horizontal and vertical installation.

Installation sequence:

- 1 Checking the number of pre-fabricated holes at the points of fixation.
- 2 Fixing the facade element through the pre-fabricated holes on fixing plate with the wind load screw.
- 3 Keeping in mind not to overtighten the screws as local deformation in the external steel skin of rain-screen element may occur

After all fixing elements are mounted, transversal gasket with a decorative extrusion is inserted into transversal joint. The sequence applies to horizontal and vertical installation.

- 1 Decorative extrusion and transversal gasket
- 2 Fixing screw (wind load)
- 3 Junction drip element
- 4 Installation centering cross B-B
- 5 Load bearing fixing plate



After Qbiss Screen element is positioned by using the installation centering cross, the element is fixed with two screws on each side through laps (vertical load fixation). Required distance between fixings, depends on element module width (M). Distribution of fixing elements and screws is the same for horizontal and vertical installation.

Installation sequence:

- 1 Checking the number of pre-fabricated holes at the points of fixation.
- 2 Fixing the facade element through the pre-fabricated holes on fixing plate with the wind load screw.
- 3 Keeping in mind not to overtighten the screws

After all fixing elements are mounted, transversal gasket with a decorative extrusion is inserted into transversal joint. The sequence applies to horizontal and vertical installation.

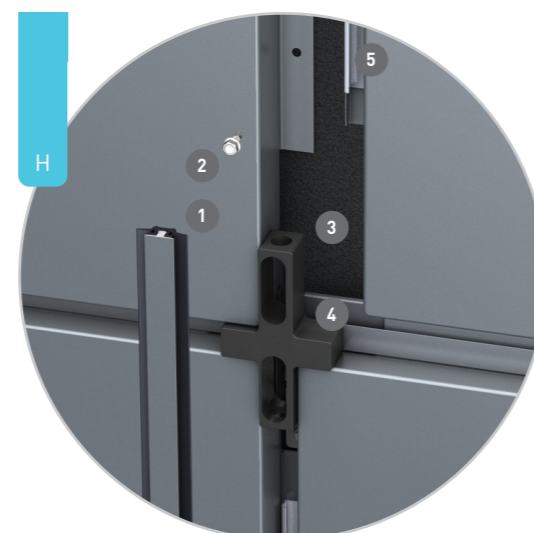

- 1 Decorative extrusion and transversal gasket
- 2 Fixing screw (wind load)
- 3 Electrochemical potential isolation tape
- 4 Installation centering cross B-B
- 5 Load bearing fixing plate

Qbiss Screen additional installation accessories

	ADDITIONAL ACCESSORIES	MW	H	H+	ELEMENT FUNCTION
1	EPDM drip element*	•			sealing of the transversal joint at drain detail
2	Screw for Qbiss Screen façade elements	•	•	•	fixing of Qbiss Screen elements
3	Wind load and lap joint fixing screw		•	•	fixing of Qbiss Screen elements
4	Vertical load fixing screw	•			fixing through element internal metal skin
5	Decorative extrusion (HF 40, 52, 64)	•	•	•	unified visual appearance of transversal joint
6	EPDM cube gasket	•	•	•	for better visual appearance and sealing of joint ends
7	Transversal gasket	•	•	•	sealing of the transversal joint
8	Junction drip element	•			sealing of the joint detail
9	Load bearing plate	•	•		
10	Load bearing fixing element HF 63			•	helps to position screws during installation
11	Dripping edge for vertical joint	•			
12	Mastic seal	•	•	•	
13	Electrochemical potential isolation tape	•	•	•	prevents electrochemical potential
14	PE-butyl tape	•	•		

* Delivered separately with the required number of units.
Each Qbiss Screen order comes with installation kit (1 installation kit / 500m² Qbiss Screen quantity).

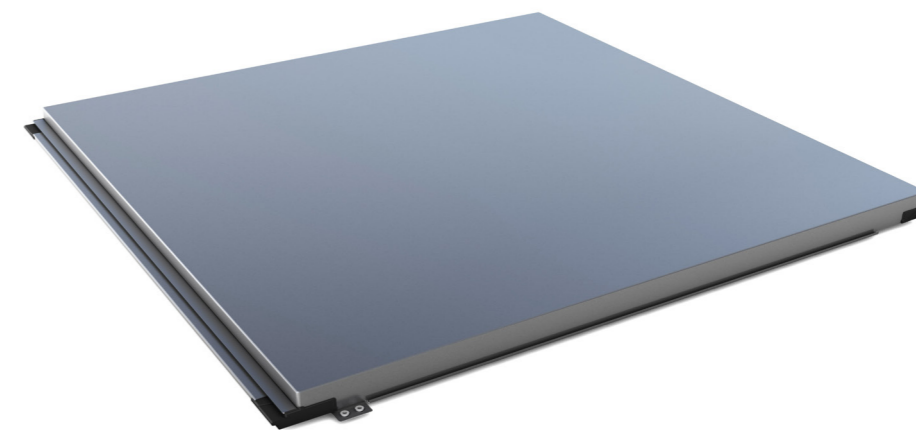

PREPARATION FOR INSTALLATION

HANDLING AND LIFTING OF QBISS SCREEN ELEMENTS

In order to handle and lift the elements, vacuum grippers are recommended. To perform installation according to the instructions, special tools are required.

Wear personal protective equipment (PPE) and assure safe working environment according to local health and safety regulations. If in doubt, contact local safety manager/engineer.

When lifting facade elements from the package, start lifting it very slowly to release it from the element beneath. Do not drag or slide lifted element, because the element beneath will be damaged and scratched. Carry elements in a vertical position.

Use of vacuum grippers are recommended. To use vacuum equipment, manufacturer's instructions must be followed.

Vacuum gripper attached to crane

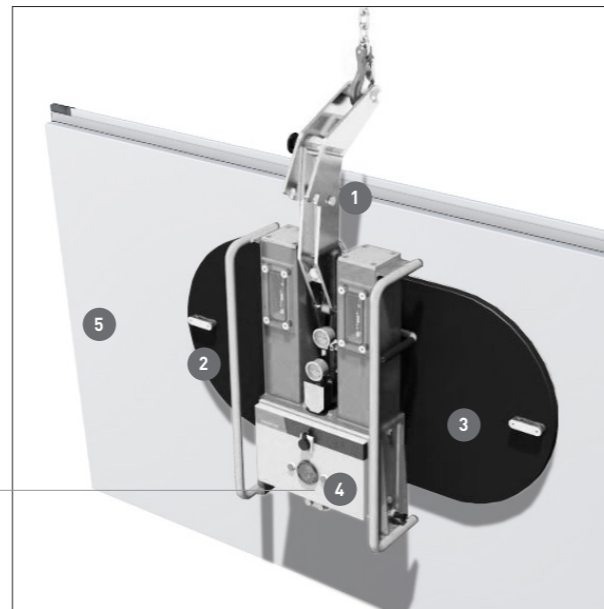

- 1 Lifting eye
- 2 Solid grips
- 3 Suction cups
- 4 Controls
- 5 Qbiss Screen horizontally laid element

For additional information about packing, manipulation, transportation and storage of Qbiss Screen elements check:

[🌐 Packing, transport and storing for Trimo products](#)

! Specific requirements for handling elements manufactured by Trimo. Manipulation carried out only with certified vacuum manipulators for panels. The maximum suction under pressure of vacuum suction cups is 30 kPa.

For safe use, follow manufacturer's instructions. Handle carefully! Installation team is responsible to check and use the correct type of vacuum grippers (octopus), suitable for lifting of self-supporting façade elements.



Small hand vacuum grippers

REMOVING THE PROTECTIVE FOIL

Qbiss Screen elements have a protective foil on outer and optionally on inner surface to protect the coloured surfaces against eventual minor scratches during transport, handling and installation.

Before Qbiss Screen element installation it is necessary to:

- Completely remove the protective foil from element's back side skin.
- Partially remove the protective foil prior to installation from the element's front side skin, at the fixing locations, both longitudinal joints, under edges, etc.

Foil needs to be removed completely when installation is completed at the latest by the end of work day.

Removing of the protective foil



- ! • When storing the products in original packaging according to storage instructions the foil must be removed within three months.
- When storing Qbiss Screen façade elements outside, they must be protected from direct sunlight, otherwise, the foil cannot be removed completely.
- At the time of installation, the foil must be removed from all joints of Qbiss Screen elements.
- Every day after the installation ends, the foil must be completely removed from each façade element / façade.
- Facade elements must be protected from water and other liquids seeping into the core during unloading, until the end of installation.

INSTALLATION PREFERENCES

INSTALLATION REQUIREMENTS

Before the installation starts, check the actual state of the building and check the placement of the substructure according to project design.

SUBSTRUCTURE

- The base support of Qbiss Screen ventilated façade system must be horizontally levelled, otherwise, the vertical joints will not be of the same width.
- Permissible tolerances of the substructure for the Qbiss Screen façade are shown in a diagram.
- For already installed substructure, the distances between vertical support must be checked for horizontal installation and distances between horizontal support must be checked for vertical installation.

The functionality of Qbiss Screen rainscreen can only be guaranteed if it is installed according to the following requirements.

HORIZONTAL ALIGNMENT OF THE BASE SUPPORT ANGLE

To ensure correct horizontal alignment of base support angle, measurements must be performed.

The permissible deviations of alignment for the base load-bearing ending must satisfy two conditions:

- **Permissible deviation along the whole length of individual Qbiss Screen façade elements is ± 0.5 mm.**
- **Permissible deviation of alignment of the complete building façade is ± 2 mm.**



The measurement procedure for ensuring the horizontal alignment of the base support.



It is crucial to ensure the contact surface of the first row of Qbiss Screen façade elements is levelled, otherwise, irregular vertical placing of Qbiss Screen elements will occur, causing size increases of transversal joints. Consequently, the transversal joints will not be properly sealed.

VERTICAL ALIGNMENT OF THE STRUCTURE / SUBSTRUCTURE

To ensure vertical alignment of the structure or substructure perpendicular to the façade surface, measurements must be performed.

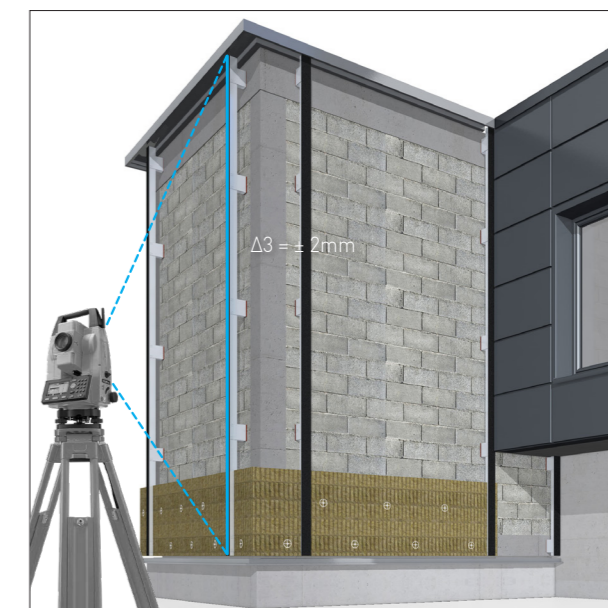

The measurement procedure for ensuring the vertical alignment of the substructure for horizontal installation.



It is crucial to connect corner elements properly, otherwise ventilated façade will be inclined, causing a loss of visual appearance of façade.

FAÇADE RASTER

Distances between vertical supports and the total distance of the substructure must be measured in order to check for eventual deviations.



The measurement procedure checking the distances between vertical supports and determining the difference between planned and actual distances.



The distances between vertical supports differ from those specified in the design and the actual distances. Before installing Qbiss Screen ventilated façade elements, deviations must be measured. The deviations can be compensated using the Qbiss Screen elements with the transversal joint tolerance by compressing or expanding the area by $^{+2} /_{-1}$ mm.



SUBSTRUCTURE DEVIATION

- Δ1 Deviations of the vertical substructure in plan view from the building axis in façade direction.
Δ1 = ± 2 mm
- Δ2 Deviation of the distance between two vertical substructions.
Δ2 = ± 2 mm
- Δ3 Deviations of the vertical substructure to the back-side of the rainscreen.
Δ3 = ± 2 mm

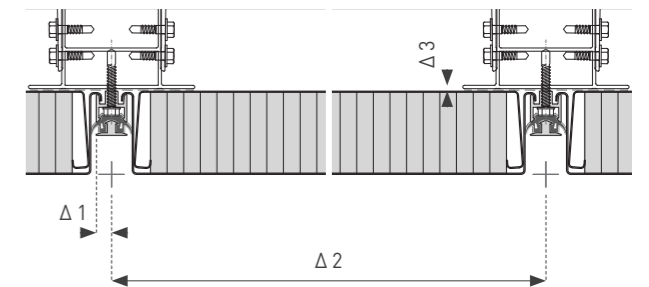

Substructure deviation.



The permissible deviations for distances between verticals are ± 2 mm, however, they must not add up.

The transversal joint of the Qbiss Screen ventilated façade system allows some tolerance for façade structure / substructure deviations, up to $^{+2} /_{-1}$ mm.

This is crucial to ensure that all transversal joints are of the right width. Otherwise, narrowing or widening of the joint can occur. Consequently, it will be impossible to finish the transversal joints.

HORIZONTAL INSTALLATION STEPS

INSTALLATION STEP 1 SUBSTRUCTURE AND BASE DETAIL

NOTES / Wear personal protective equipment (PPE) and ensure safe working environment according to local health and safety regulations. Beware of sharp corners and edges. If in doubt contact local safety manager/engineer.

All Qbiss Screen joint variations follow the same basic Qbiss Screen B-B system installation steps. Before the installation, check the actual state of the building and inspect the placement of the substructure in relation to raster and according to project design. Qbiss Screen base support depends on the type of load bearing profiles.

Before start of installation assure that substructure is installed according to tolerances.

[🔗 Link to installation methods chapter](#)



SUPPORT FOR THE FAÇADE ELEMENT, BASE DETAIL

- 1 Internal structural wall
- 2 Aluminium substructure – load bearing profile
- 3 Thermal insulation for ventilated façade (mineral wool)
- 4 Base support for thermal insulation
- 5 Base load-bearing profile for Qbiss Screen façade element
- 6 Perforated section – insect protection
- 7 Fixing screws
- 8 Load bearing profile isolator
- 9 Electrochemical potential isolation tape

The substructure specified by supplier of substructure consists of the following components:

- Brackets made from metal or fiber-reinforced plastics or combinations of these materials
- Stand-off bolts or distance pieces
- Thermal separators / isolators
- Anchor components
- Load-bearing profiles (L, T, Z, U, Ω - profiles)
- Fasteners

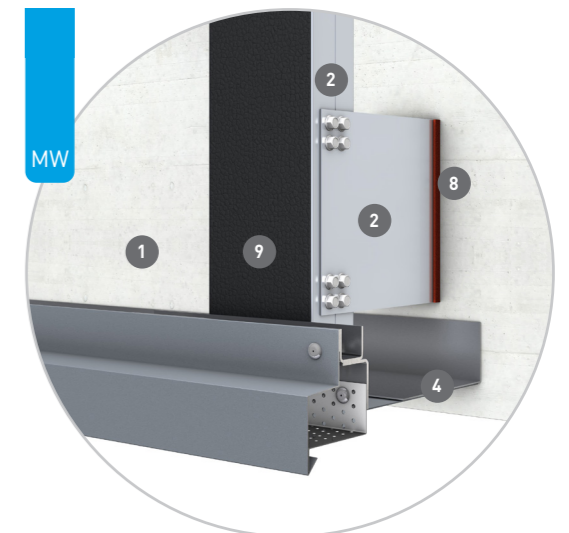
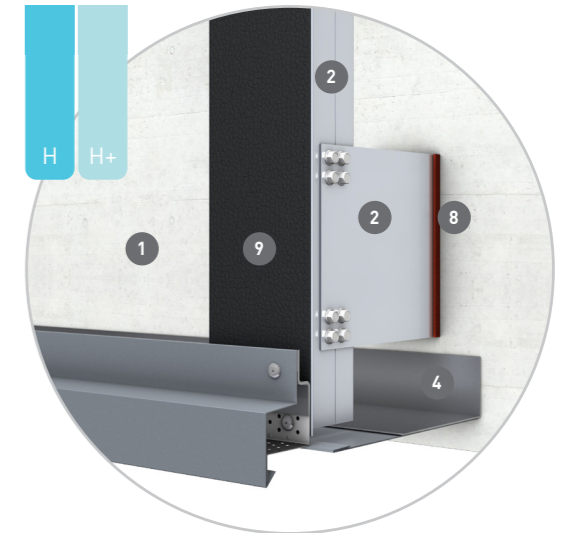
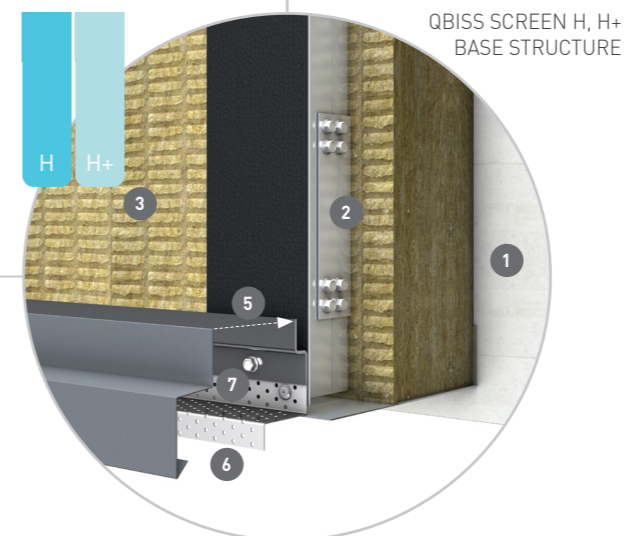
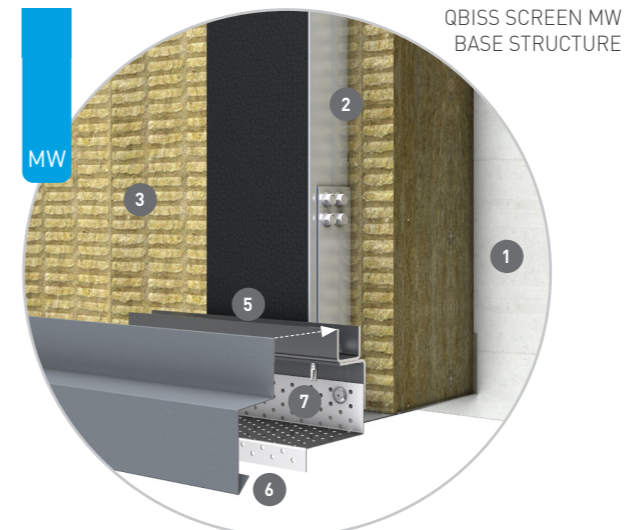

- !
- Prior to Qbiss Screen ventilated façade element installation, the substructure-geometry must be checked.
 - The base load-bearing profile must be laid horizontally, otherwise, the uniformity of the horizontal and vertical joints of Qbiss Screen ventilated façade system cannot be guaranteed.
 - The horizontal alignment of the substructure must be checked using a suitable measuring equipment. This device must be used to ensure that the elements are laid horizontally.

INSTALLATION STEP **2** **FACADE ELEMENTS INSTALLATION**

NOTES / Follow installation direction as defined in elevation drawings and as described in installation methods chapter. Start with installation of the first first row of Qbiss Screen elements. Position each element with installation centering cross and horizontally align top edge with adjacent façade elements (put a level across vertical/transversal joint). Once the element is positioned, fix it with screws. Continue with installation of remaining elements. Windows, door frames and other openings are installed simultaneously with the Qbiss Screen ventilated façade elements.

Joint detail installation sequence:

1. Insert the installation cross into the joint between three already installed Qbiss Screen façade elements.
2. Place the Qbiss Screen façade element on the bottom Qbiss Screen façade element, to form a longitudinal joint and aligned transversal joint.
3. Checking the level / horizontal alignment of two adjacent façade elements through vertical / transversal joint and make adjustment. Insert junction drip element (Qbiss Screen MW).
4. Perform self-weight load fixing with screws through the lap joints on the internal steel skin (Qbiss Screen H, H+).
5. Install screw for wind load fixing.

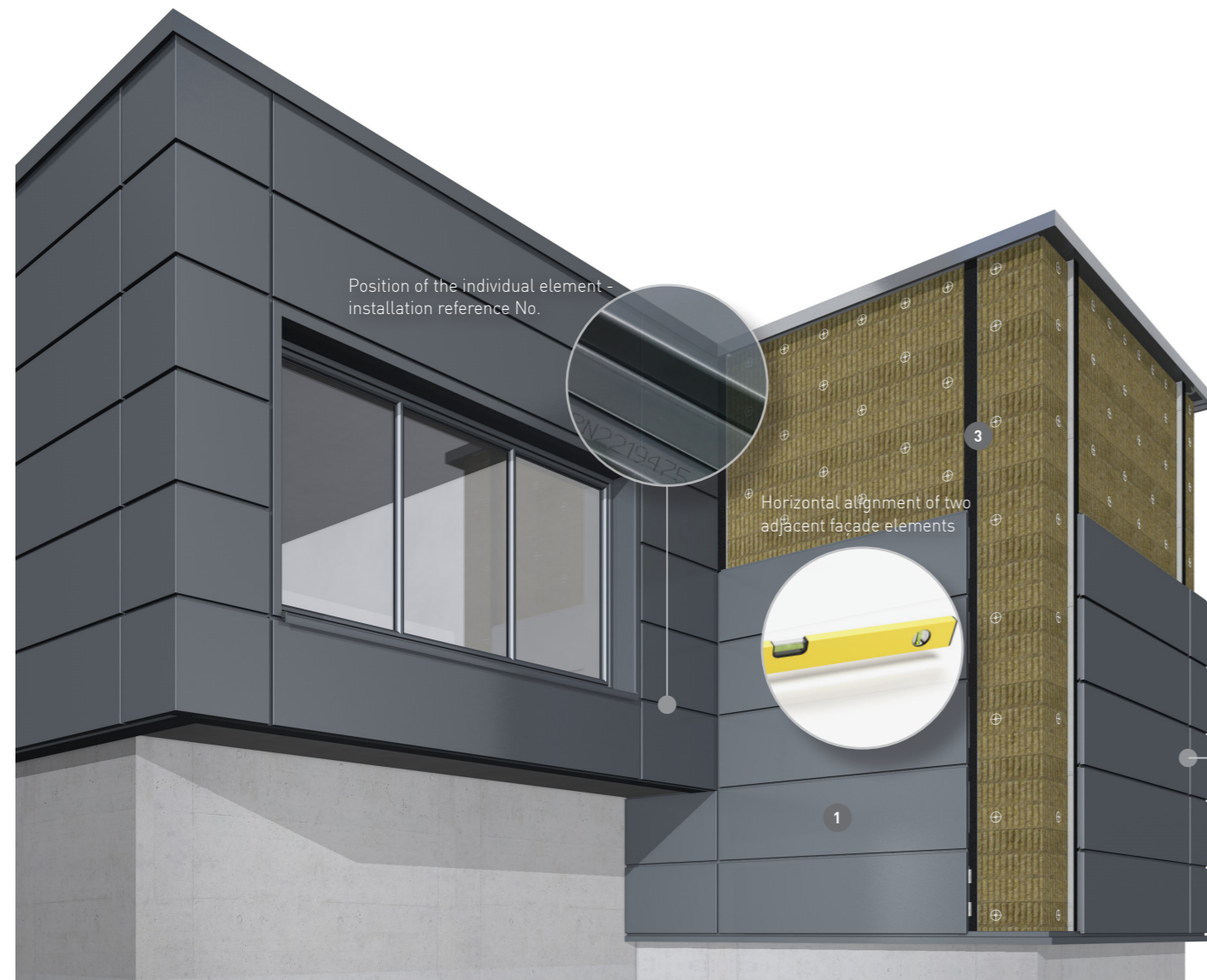

QBISS SCREEN ELEMENT INSTALLATION, JOINT DETAIL

1. Qbiss Screen façade element – already installed
2. Qbiss Screen façade element – to be installed
3. Substructure – load bearing profile
4. Electrochemical potential isolation tape
5. Upper prefabricated lap, A-side
6. Bottom prefabricated lap, A-side
7. Upper prefabricated lap, B-side
8. Bottom prefabricated lap, B-side
9. Screws - wind load fixing
10. Qbiss Screen B-B installation centering cross
11. Qbiss Screen H+ installation cross spacer
12. Junction drip element (Qbiss Screen MW)

- [Link to corner elements chapter](#)
- [Link to installation methods chapter](#)

Position of lap joint flange with stubend in lap joint on Qbiss Screen facade element.

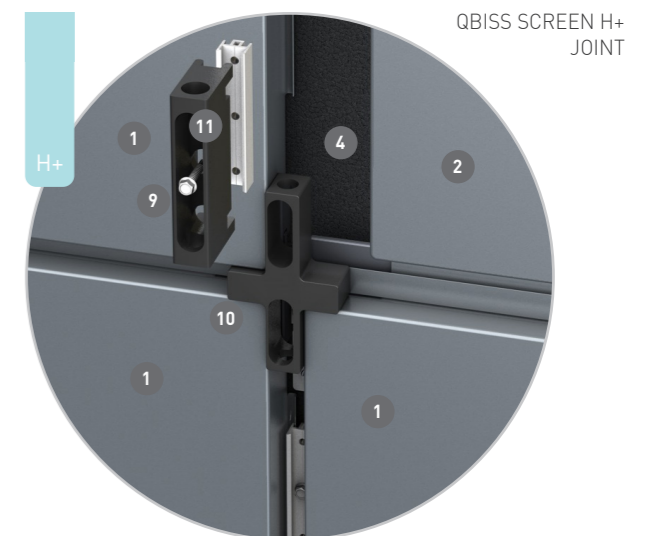
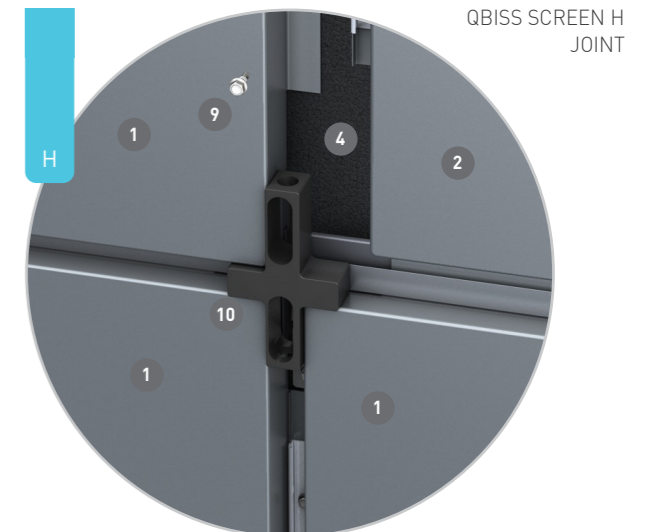
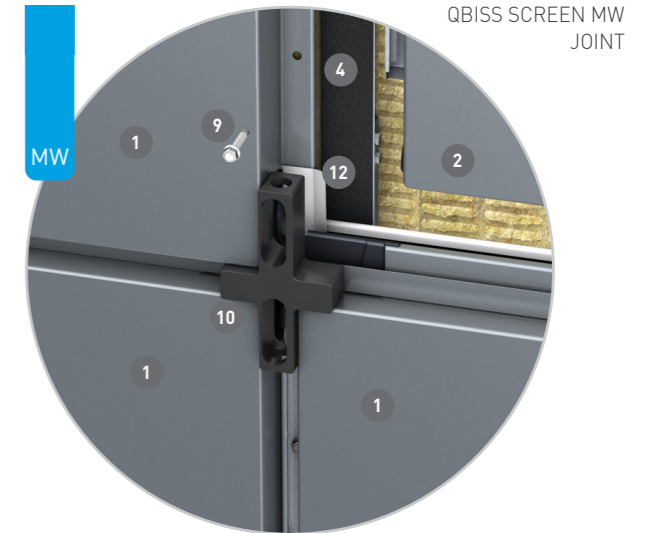
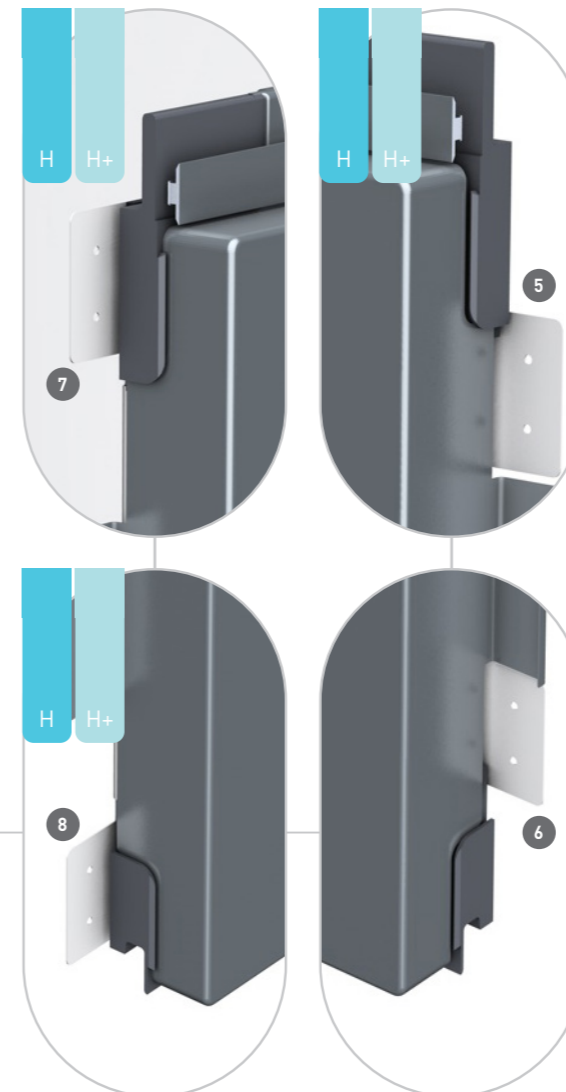

INSTALLATION STEP 3 CORNER ELEMENTS INSTALLATION

NOTES / Before fixing the Qbiss Screen corner element, vertical and horizontal level of substructure need to be inspected and levelled. Horizontal alignment of two adjacent Qbiss Screen ventilated façade elements through vertical / transversal joint must be regularly checked using installation centering cross.

Corner detail installation sequence:

- 1 Insert the installation cross into the joint between three already installed Qbiss Screen ventilated façade elements. Two elements on the side can be either façade elements or corner elements. The bottom side element is a façade element.
- 2 Place the Qbiss Screen corner element onto the bottom Qbiss Screen element, to form a longitudinal joint and align transversal joint.

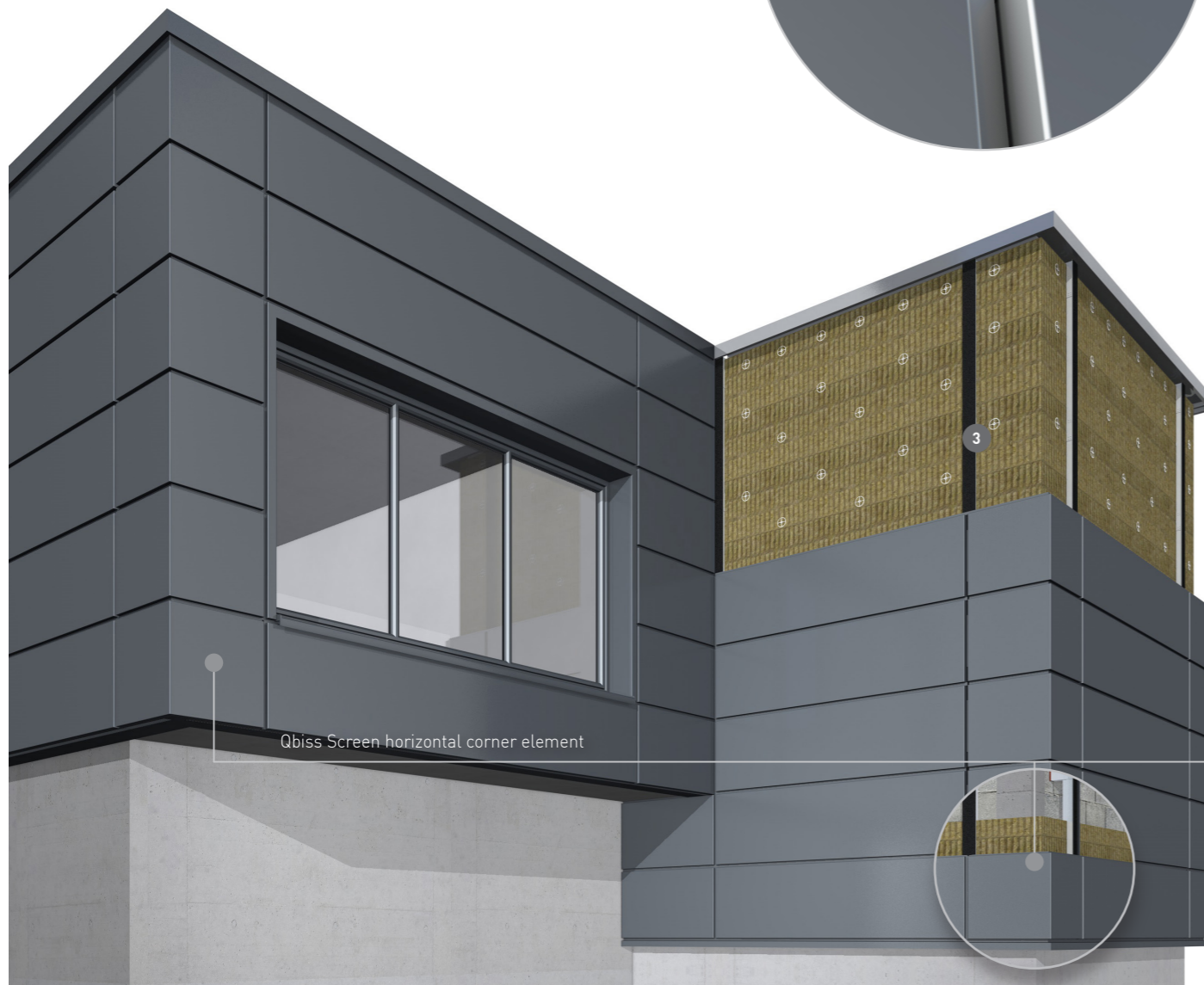
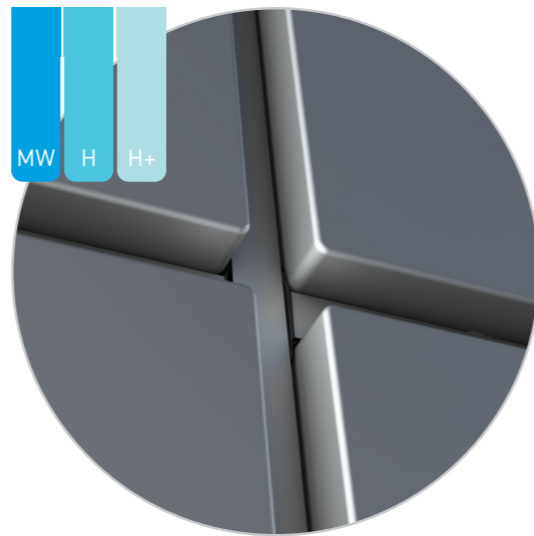

QBISS SCREEN CORNER ELEMENT INSTALLATION, CORNER DETAIL

- 1 Qbiss Screen corner element, A-side
- 2 Qbiss Screen corner element, B-side
- 3 Substructure – Load bearing profile
- 4 Screws - wind load fixing
- 5 Upper prefabricated lap, A-side
- 6 Bottom prefabricated lap, A-side
- 7 Upper prefabricated lap, B-side
- 8 Bottom prefabricated lap, B-side
- 9 Screws - self-weight load fixing
- 10 Qbiss Screen H+ installation cross spacer

[Link to corner elements chapter](#)

Position of lap joint flange with stubend in lap joint on corner element



QBISS SCREEN CORNER ELEMENT

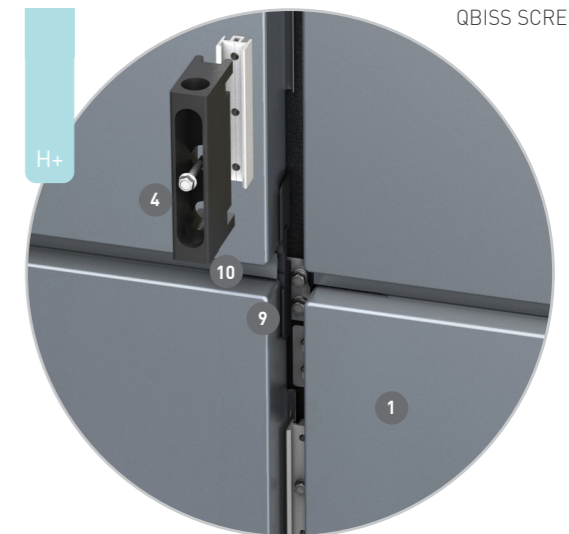
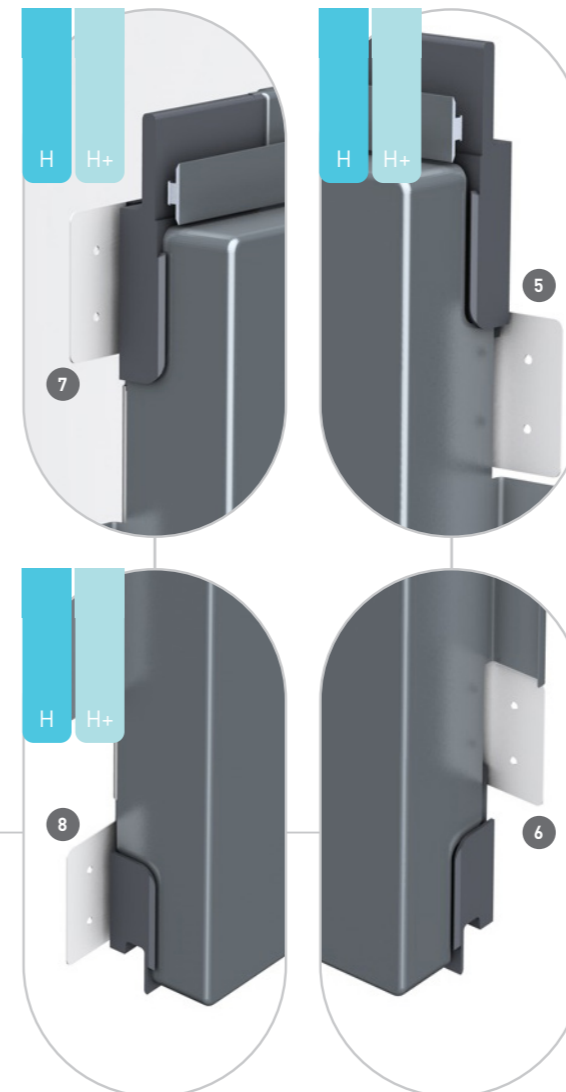

QBISS SCREEN H+ JOINT

- !
 - If a corner side is longer than 500 mm it needs to be self-weight supported at every 500 mm from transversal joint by a steel flat plate fixed to the element back-side steel skin and to substructure.
 - If a corner is U-shape formed, it needs to be self-weight supported at the middle position of mid leg at longitudinal tongue joint by a steel flat plate fixed to the element internal steel skin and to substructure.

INSTALLATION STEP 4 TRANSVERSAL GASKET INSTALLATION

NOTES / After the drip flashing is inserted, an additional sealing must be performed. Lubricant (syringe with soap-water) must be applied to reduce friction and facilitate the inserting of the transversal gasket together with decorative Al extrusion on the transversal joint. Transversal joint gasket and the decorative Al extrusion must be assembled before they are inserted into the transversal joint. The standard length of the decorative extrusion profiles is 4 m.

Extension of the profile is performed using a dilation slot of 10 mm, meaning that the profiles are not in contact.

Gasket installation sequence:

 [Link to system sealing chapter](#)

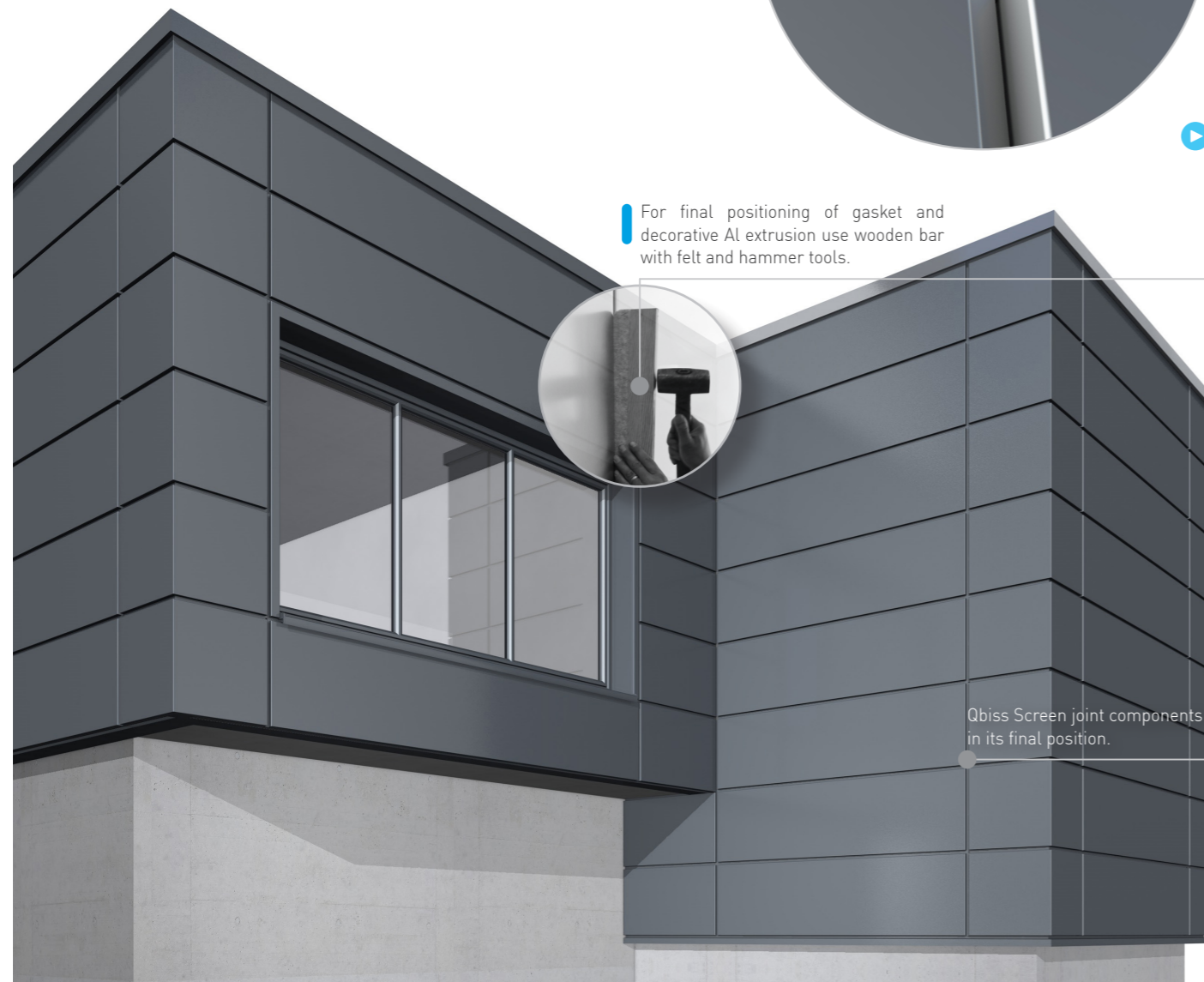
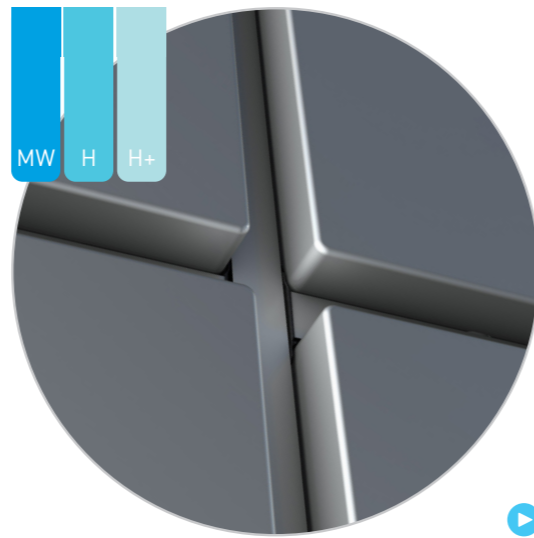

QBISS SCREEN FAÇADE ELEMENT JOINT DETAIL

1. Qbiss Screen façade element – already installed
2. Qbiss Screen façade element – installed last
3. Load bearing fixing plate
4. Electrochemical potential insulation tape
5. Qbiss Screen H+ installation cross spacer
6. Screws – wind load fixings
7. Screws – self-weight load fixings
8. Junction drip element
9. Transversal gasket together with decorative extrusion
10. Load bearing fixing element HF 63 (Qbiss Screen H+)

 [Link to system sealing chapter](#)



QBISS SCREEN H
HORIZONTAL ELEMENT



QBISS SCREEN MW
JOINT

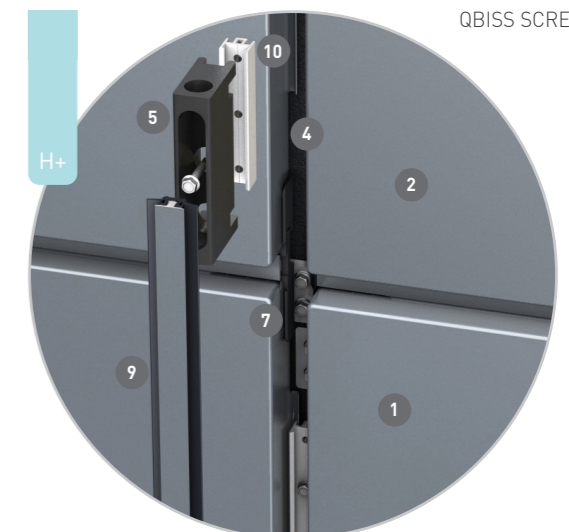

QBISS SCREEN H+
JOINT

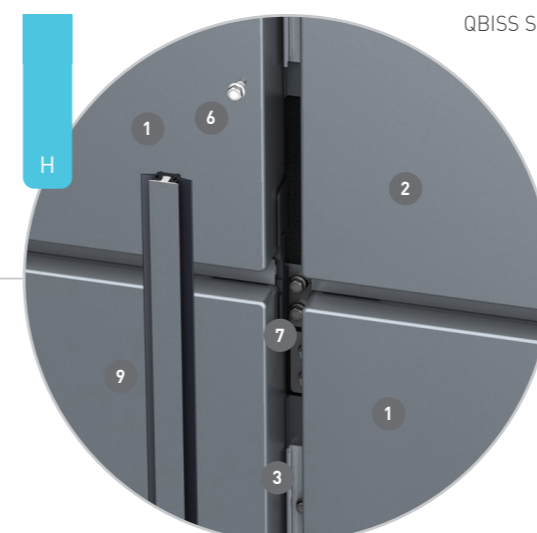

QBISS SCREEN H
JOINT

! Wooden bar with protective felt are used to insert the decorative extrusion and the transversal gasket into final position without damaging adjacent Qbiss Screen MW elements or decorative extrusion.

INSTALLATION STEP **5** PARAPET CAP AND OTHER DETAILS

NOTES / Installation of parapet cap is performed after all elements are mounted and transversal joints are installed. The parapet finish is done using a parapet cap.

Parapet wall detail installation sequence:

1. Install an insect protection mesh to the load bearing profile using screws.
2. Attach the support for the parapet wall cap through the support for the lining onto the parapet wall substructure.
3. Place the parapet wall cap on the top / final Qbiss Screen horizontal façade element.
4. Attach the parapet wall cap with a screw to the lining support. 1 screw per meter is added in longitudinal joint to avoid deflection.

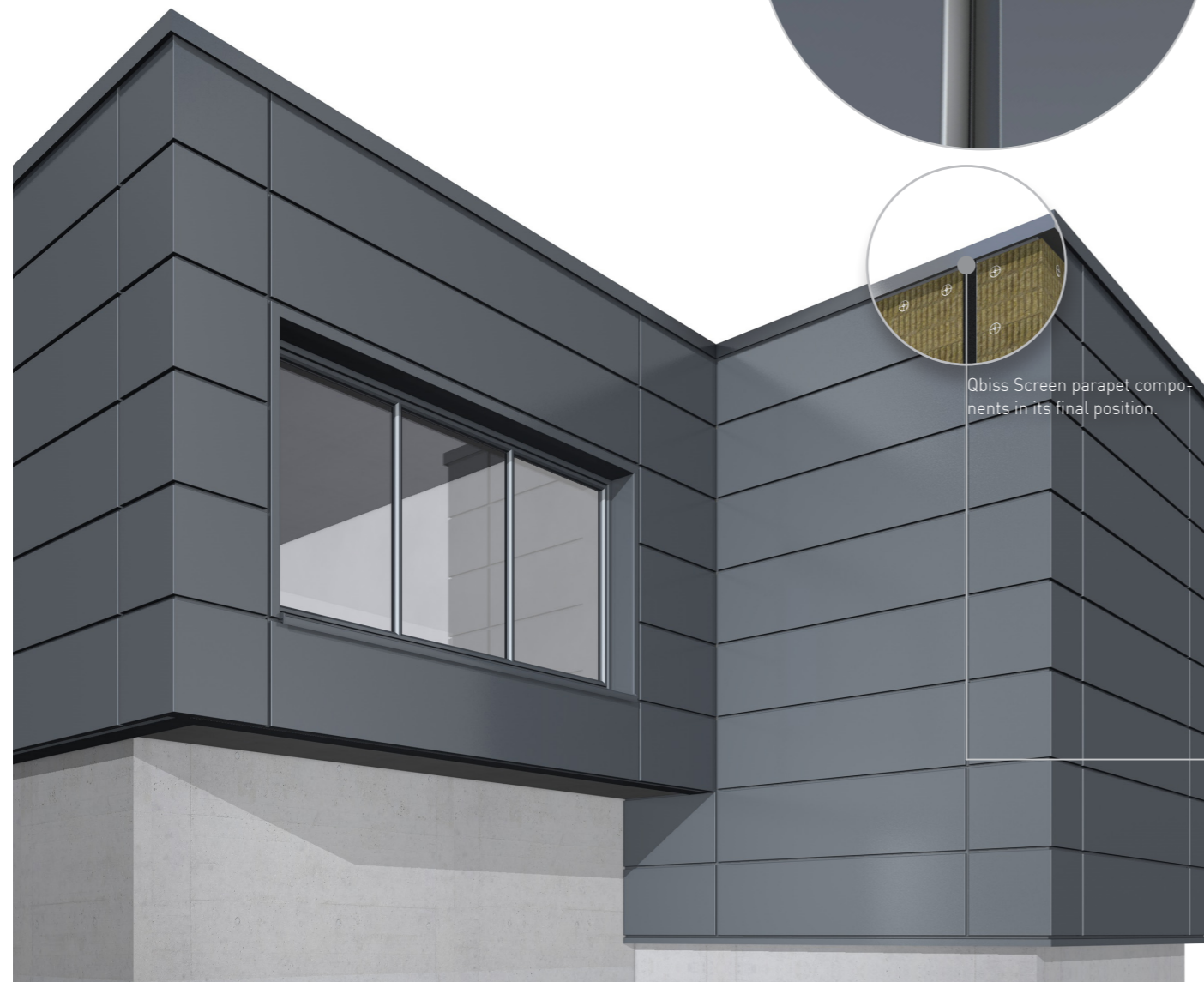
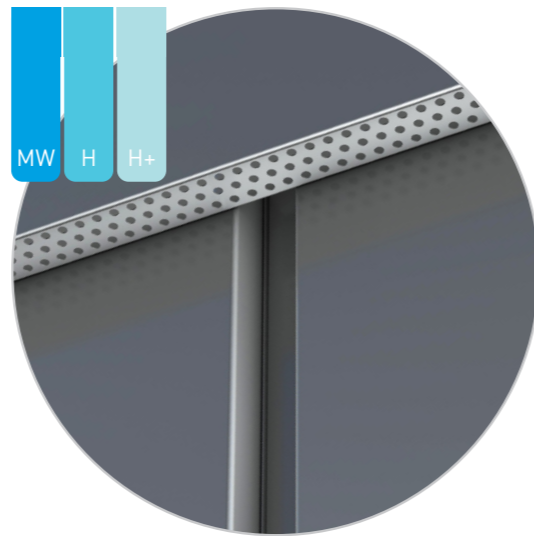

QBISS SCREEN ELEMENT INSTALLATION, PARAPET DETAIL

1. Qbiss Screen façade element
2. Decorative Al extrusion HF64 (recessed look of transversal joint)
3. Decorative Al extrusion HF40 (Qbiss Screen MW, H)
4. Transversal gasket
5. Screws – wind load fixing
6. Screws – self-weight load fixing
7. Load bearing profile
8. Load bearing fixing element HF 63 (Qbiss Screen H+)
9. Qbiss Screen parapet cap
10. Qbiss Screen outlet vents open

 [Link to design details chapter](#)

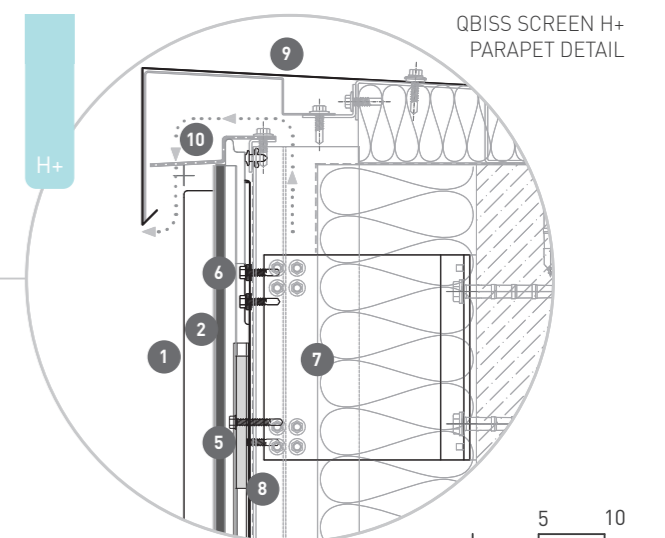
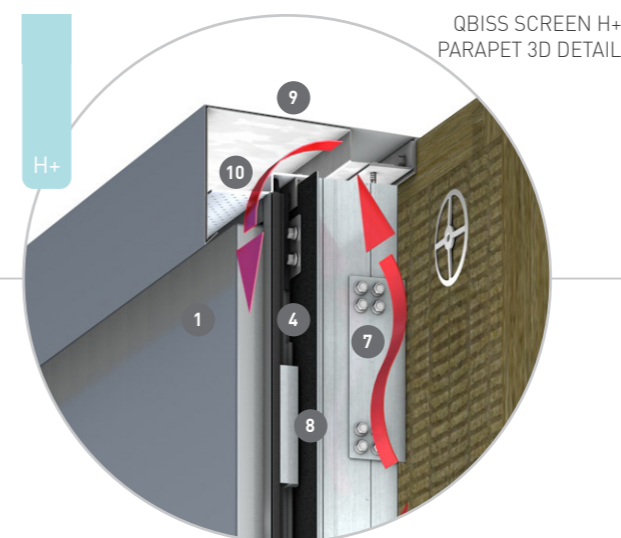
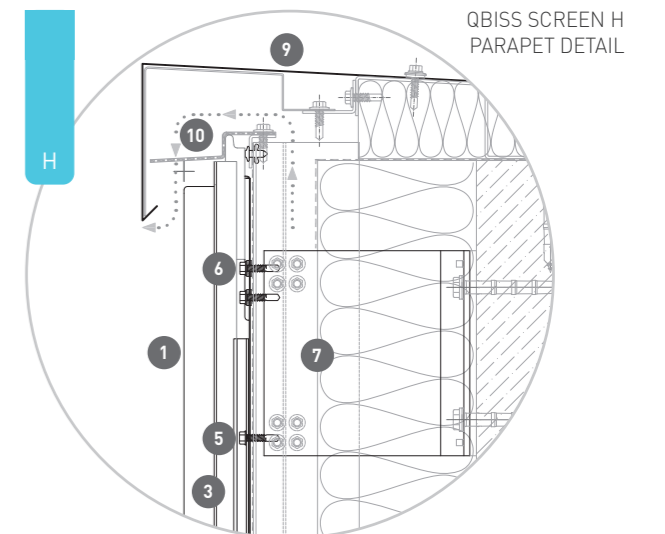
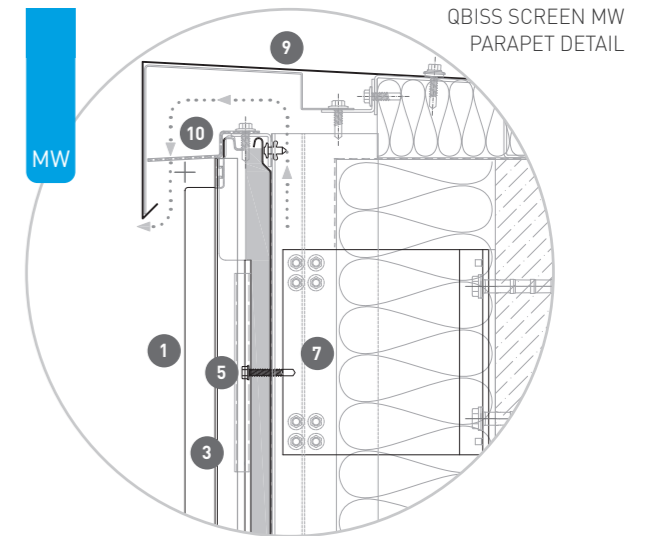

VERTICAL INSTALLATION STEPS

INSTALLATION STEP 1 SUBSTRUCTURE AND BASE DETAIL

NOTES / Wear personal protective equipment (PPE) and ensure safe working environment according to local health and safety regulations. Beware of sharp corners and edges. If in doubt contact local safety manager/engineer.

All element joint variations follow the same basic Qbiss Screen B-B system installation steps. Before starting the installation, check the actual state of the building and check the placement of the substructure against the raster in the design of particular project. Support for the Qbiss Screen façade element base depends on the type of load bearing profiles.

Before start of installation assure that substructure is installed according to tolerances.

[🔗 Link to installation preferences chapter](#)



SUPPORT FOR THE FAÇADE ELEMENT, BASE DETAIL

- 1 Internal structural wall
- 2 Aluminium substructure – load bearing profile
- 3 Thermal insulation for ventilated façade (mineral wool)
- 4 Base support for thermal insulation
- 5 Base load-bearing profile for Qbiss Screen façade element
- 6 Perforated section – insect protection
- 7 Fixing screws
- 8 Load bearing profile isolator
- 9 Electrochemical potential isolation tape

The substructure specified by supplier of substructure consists of the following components:

- Brackets made from metal or fiber-reinforced plastics or combinations of these materials
- Stand-off bolts or distance pieces
- Thermal separators / isolators
- Anchor components
- Load-bearing profiles (L, T, Z, U, Ω - profiles)
- Fasteners

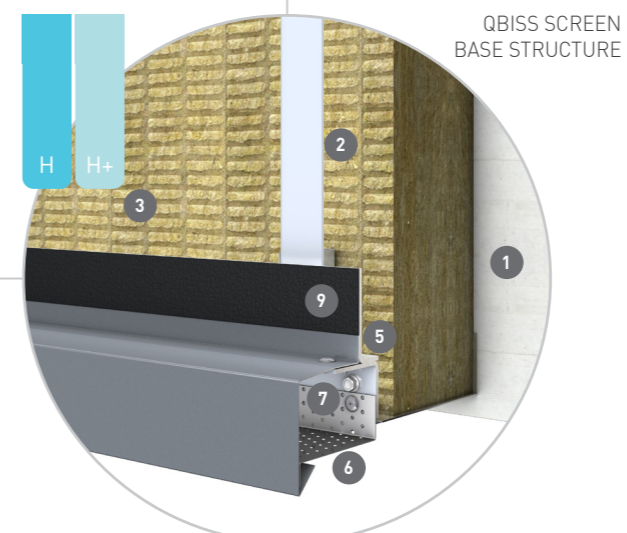
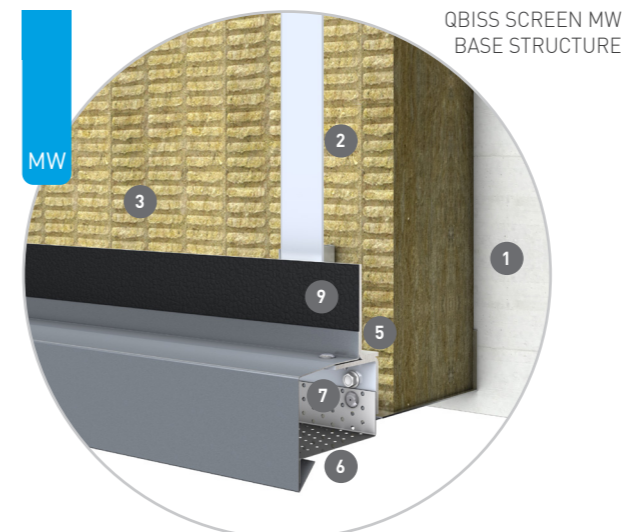
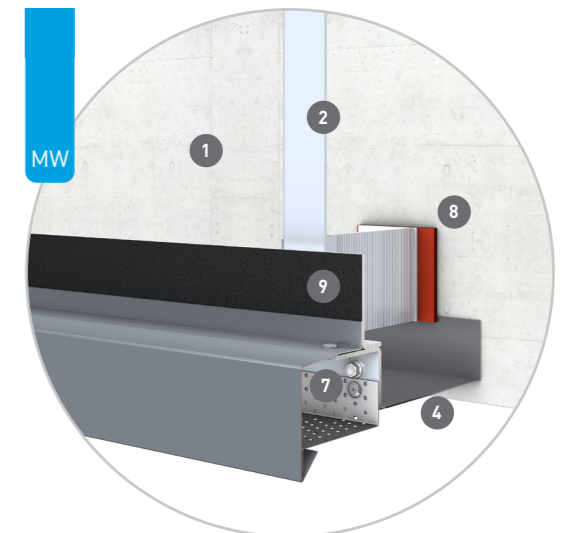
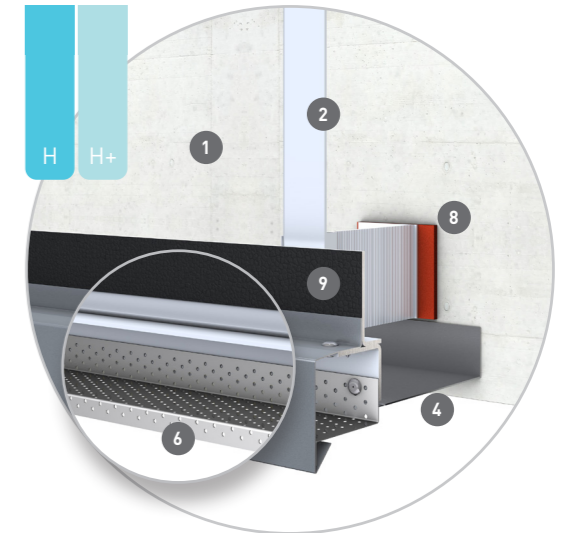

!

- Prior to Qbiss Screen ventilated façade element installation, the substructure-geometry must be checked.
- The base load-bearing profile must be laid horizontally, otherwise, the uniformity of the horizontal and vertical joints of Qbiss Screen ventilated façade system cannot be guaranteed.
- The horizontal alignment of the substructure must be checked using a suitable measuring equipment to ensure that the elements are laid horizontally within tolerances.

INSTALLATION STEP **2** **FACADE ELEMENTS INSTALLATION**

NOTES / Follow installation direction as defined in elevation drawings and as described in installation methods chapter. Start with installation of the first row of Qbiss Screen elements. Position each element with installation centering cross and horizontally align top edge with adjacent façade elements (put a level across vertical/transversal joint). Once the element is positioned, fix it with screws. Continue with installation of remaining elements. Windows, door frames and other openings are installed simultaneously with the Qbiss Screen ventilated façade elements.

Joint detail installation sequence:

- 1 Insert the installation cross into the joint between three already installed Qbiss Screen façade elements.
- 2 Place the Qbiss Screen façade element on the bottom Qbiss Screen façade element, to form a longitudinal joint and aligned transversal joint.
- 3 Checking the level / horizontal alignment of two adjacent façade elements through vertical / transversal joint and make adjustment.
- 4 Perform self-weight load fixing with screws through the lap joints on the internal steel skin (Qbiss Screen H, H+).
- 5 Install screw for wind load fixing.

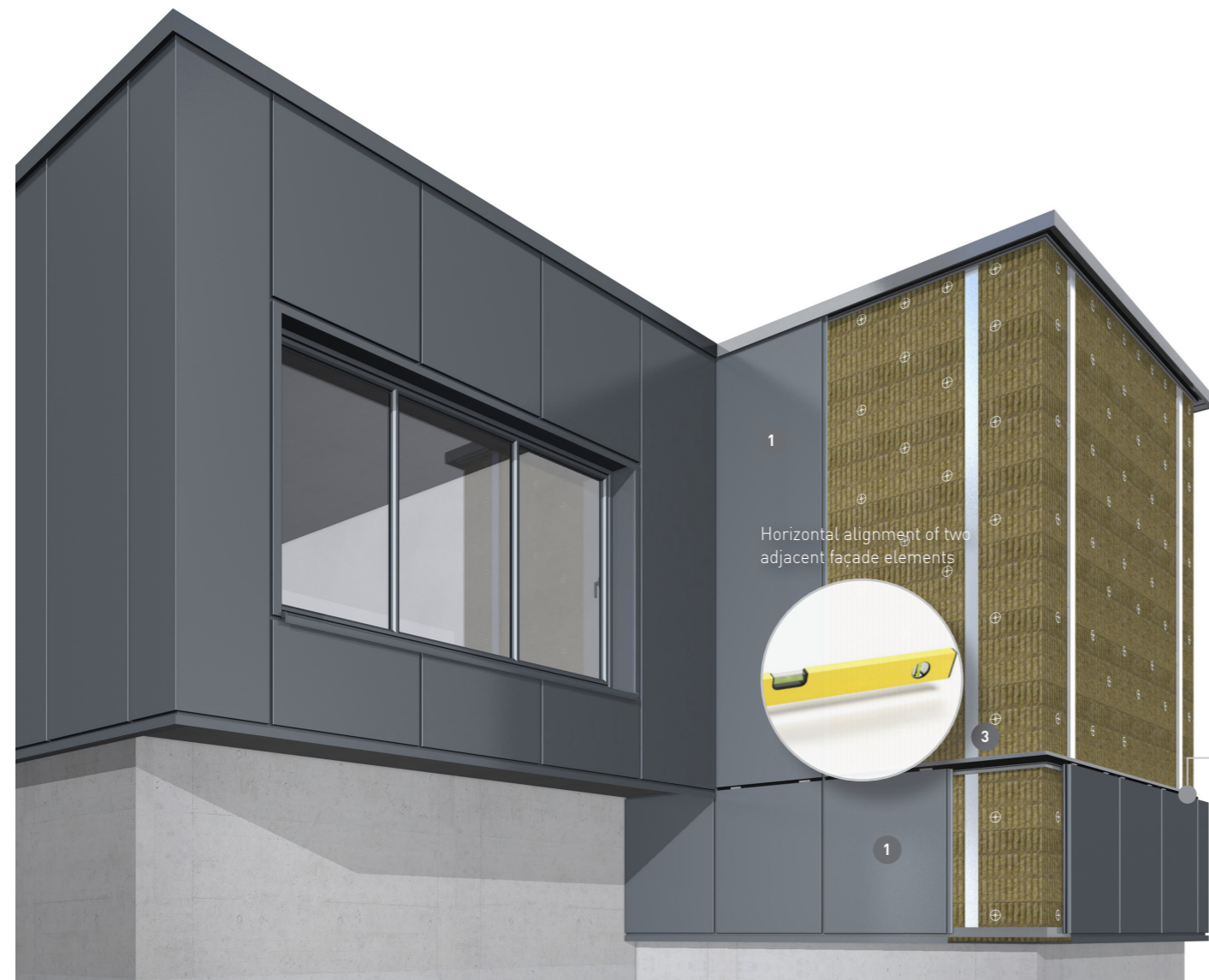

QBISS SCREEN ELEMENT INSTALLATION, JOINT DETAIL

1. Qbiss Screen façade element – already installed
2. Qbiss Screen façade element – to be installed
3. Substructure – load bearing profile
4. Electrochemical potential isolation tape
5. Upper prefabricated lap, A-side
6. Bottom prefabricated lap, A-side
7. Upper prefabricated lap, B-side
8. Bottom prefabricated lap, B-side
9. Screws - wind load fixing
10. Qbiss Screen B-B installation centering cross
11. PE-butyl tape

- [Link to corner elements chapter](#)
- [Link to installation methods chapter](#)

Position of lap joint flange with stubend in lap joint on Qbiss Screen facade element.

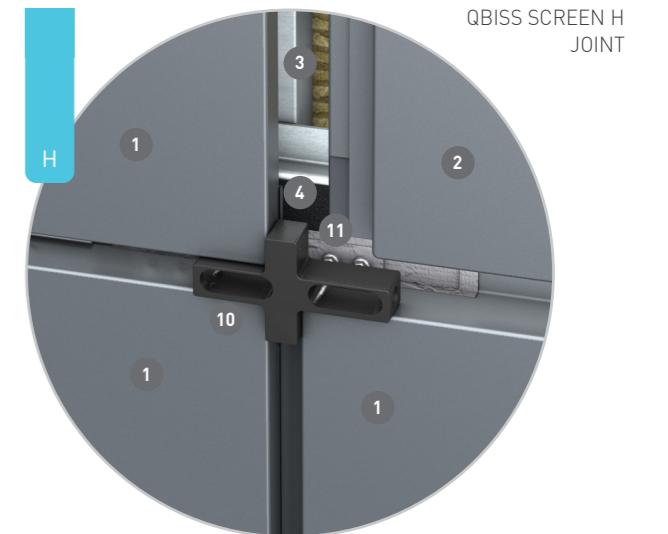
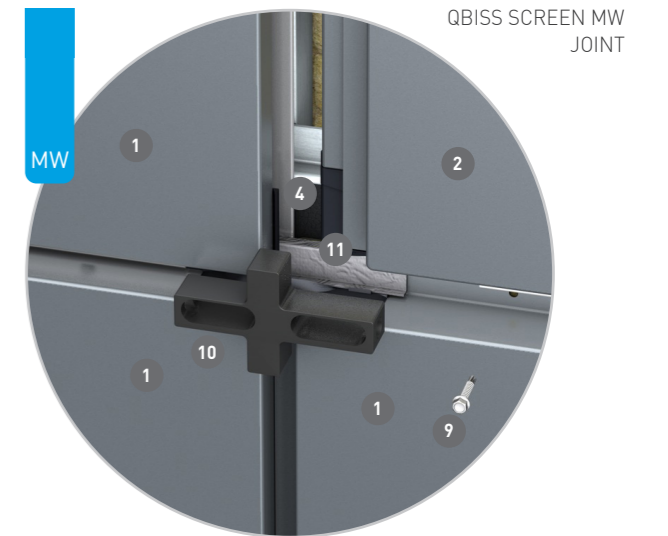
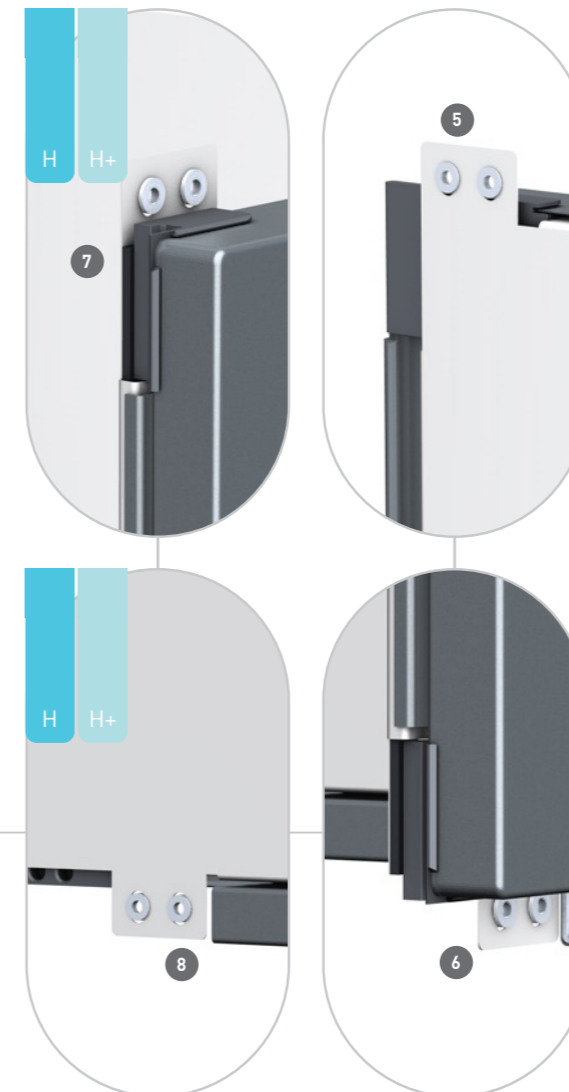

! Qbiss Screen H+ vertical element is allowed to be used as an internal wall application only.

INSTALLATION STEP 3 CORNER ELEMENTS INSTALLATION

NOTES / Before fixing the Qbiss Screen corner element, vertical and horizontal level of substructure need to be inspected and levelled. Horizontal alignment of two adjacent Qbiss Screen ventilated façade elements through vertical / transversal joint must be regularly checked using installation centering cross.

Corner detail installation sequence:

- 1 Insert the installation cross into the joint between three already installed Qbiss Screen ventilated façade elements. Two elements on the side can be either façade elements or corner elements. The bottom side element is a façade element.
- 2 Before Qbiss Screen corner is installed you need to loosen up the fixation of the neighbouring elements in order to facilitate the installation of the element joints in connection to the neighboring elements. Place the Qbiss Screen corner element onto the bottom Qbiss Screen element, to form a longitudinal joint and align transversal joint.

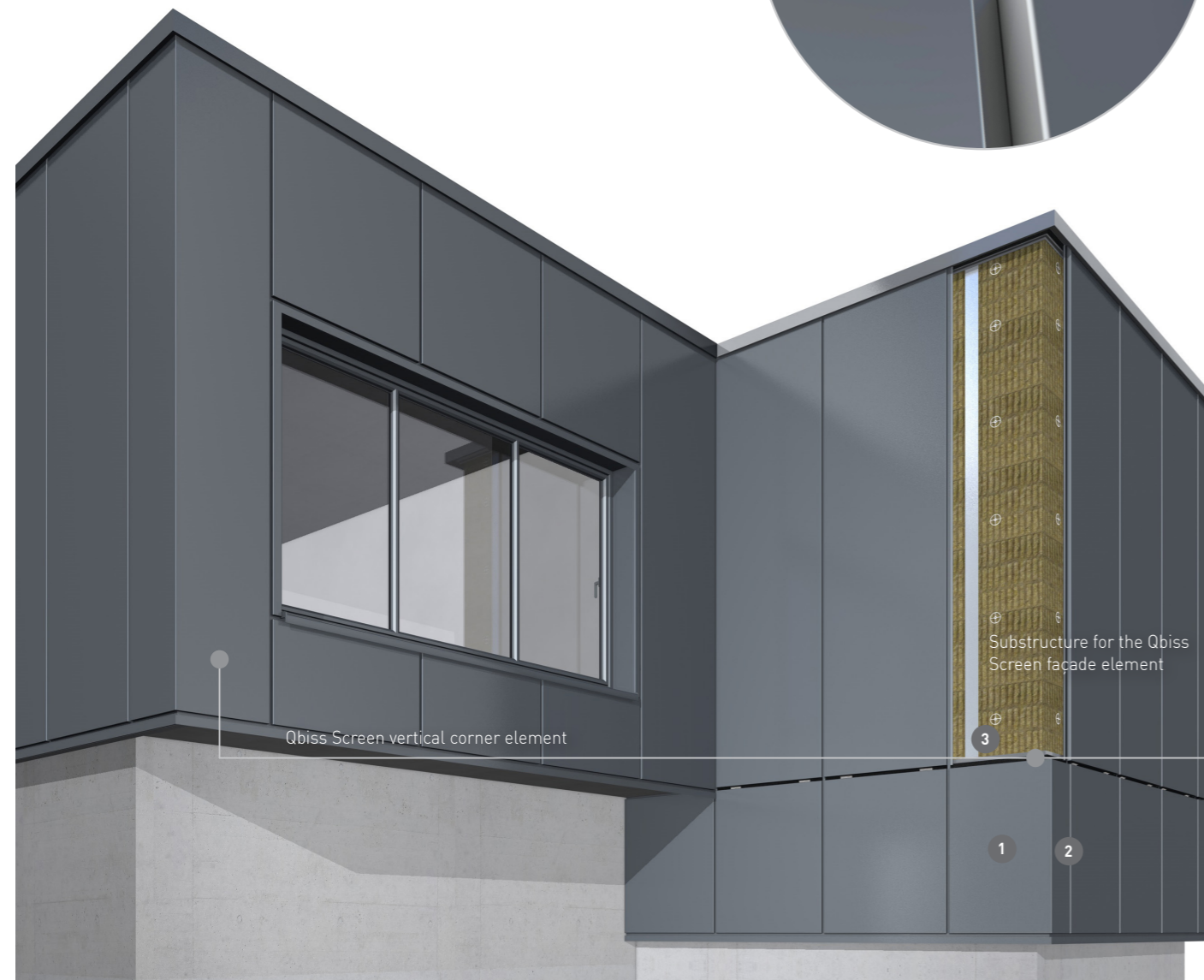
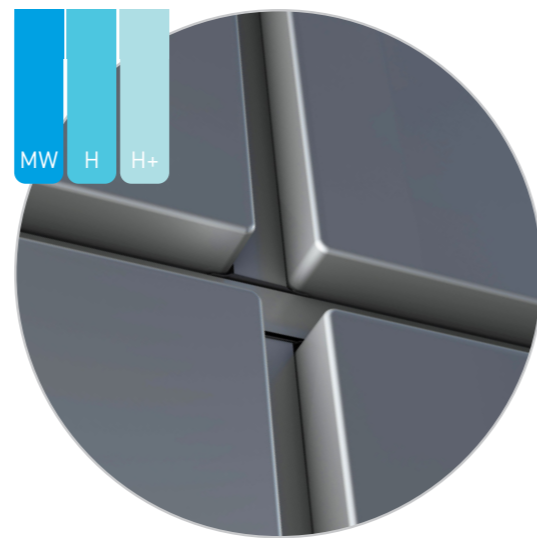
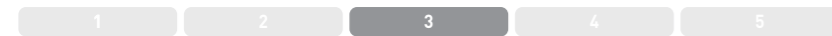

QBISS SCREEN CORNER ELEMENT INSTALLATION, CORNER DETAIL

- 1 Qbiss Screen corner element, A-side
- 2 Qbiss Screen corner element, B-side
- 3 Substructure – Load bearing profile
- 4 Screws - wind load fixing
- 5 Upper prefabricated lap, A-side
- 6 Bottom prefabricated lap, A-side
- 7 Upper prefabricated lap, B-side
- 8 Bottom prefabricated lap, B-side
- 9 Screws - self-weight load fixing
- 10 Electrochemical potential isolation tape

[Link to corner elements chapter](#)

Position of lap joint flange with stubend in lap joint on corner element

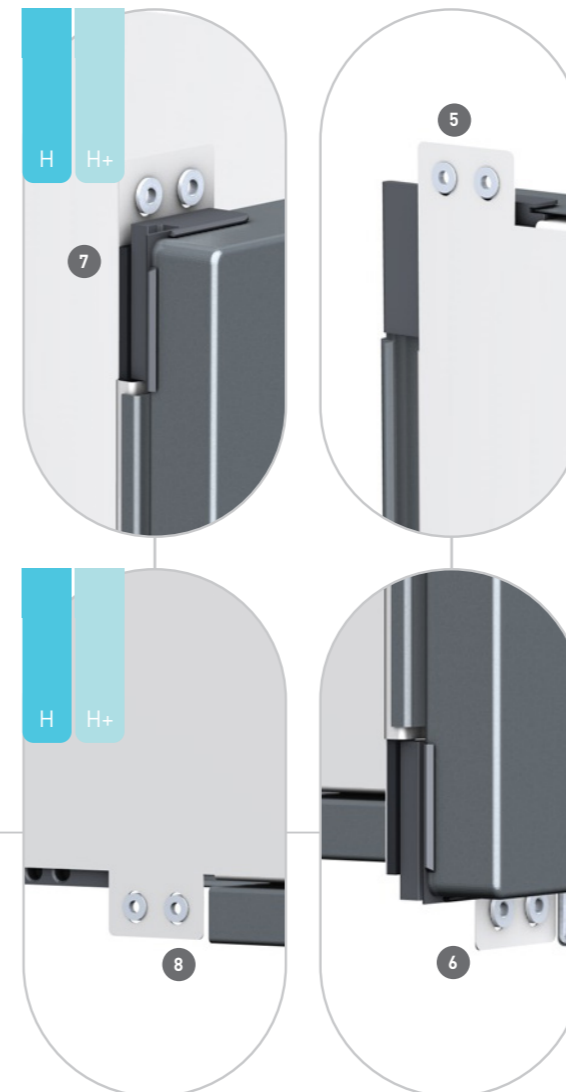

QBISS SCREEN H CORNER ELEMENT

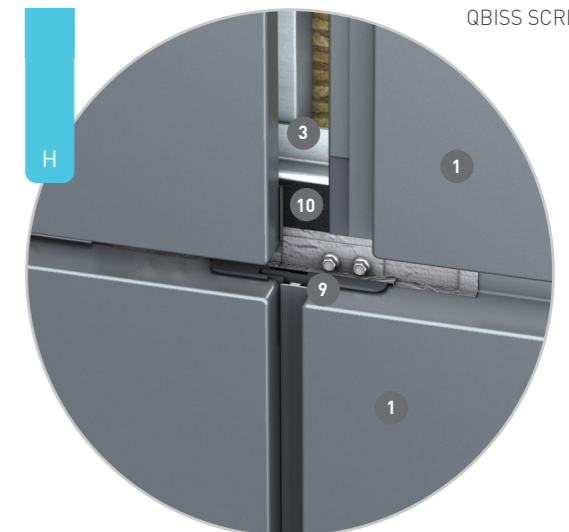

QBISS SCREEN H JOINT

- ! If a corner side is longer than 500 mm it needs to be self-weight supported at every 500 mm from transversal joint by a steel flat plate fixed to the element back-side steel skin and to substructure.
- ! If a corner is U-shape formed, it needs to be self-weight supported at the middle position of B-side at longitudinal tongue joint by steel flat plate fixed to the element internal steel skin and to substructure.

INSTALLATION STEP **4** TRANSVERSAL GASKET INSTALLATION

NOTES / After the drip flashing is inserted, an additional sealing must be performed. Lubricant (syringe with soap-water) must be applied to reduce friction and facilitate the inserting of the transversal gasket together with decorative Al extrusion on the transversal joint. Transversal joint gasket and the decorative Al extrusion must be installed before they are inserted into the transversal joint. The standard length of the decorative extrusion profiles is 4 m.

Extension of the profile is performed using a dilation slot of 10 mm, meaning that the profiles are not in contact.

Gasket installation sequence:

 [Link to system sealing chapter](#)

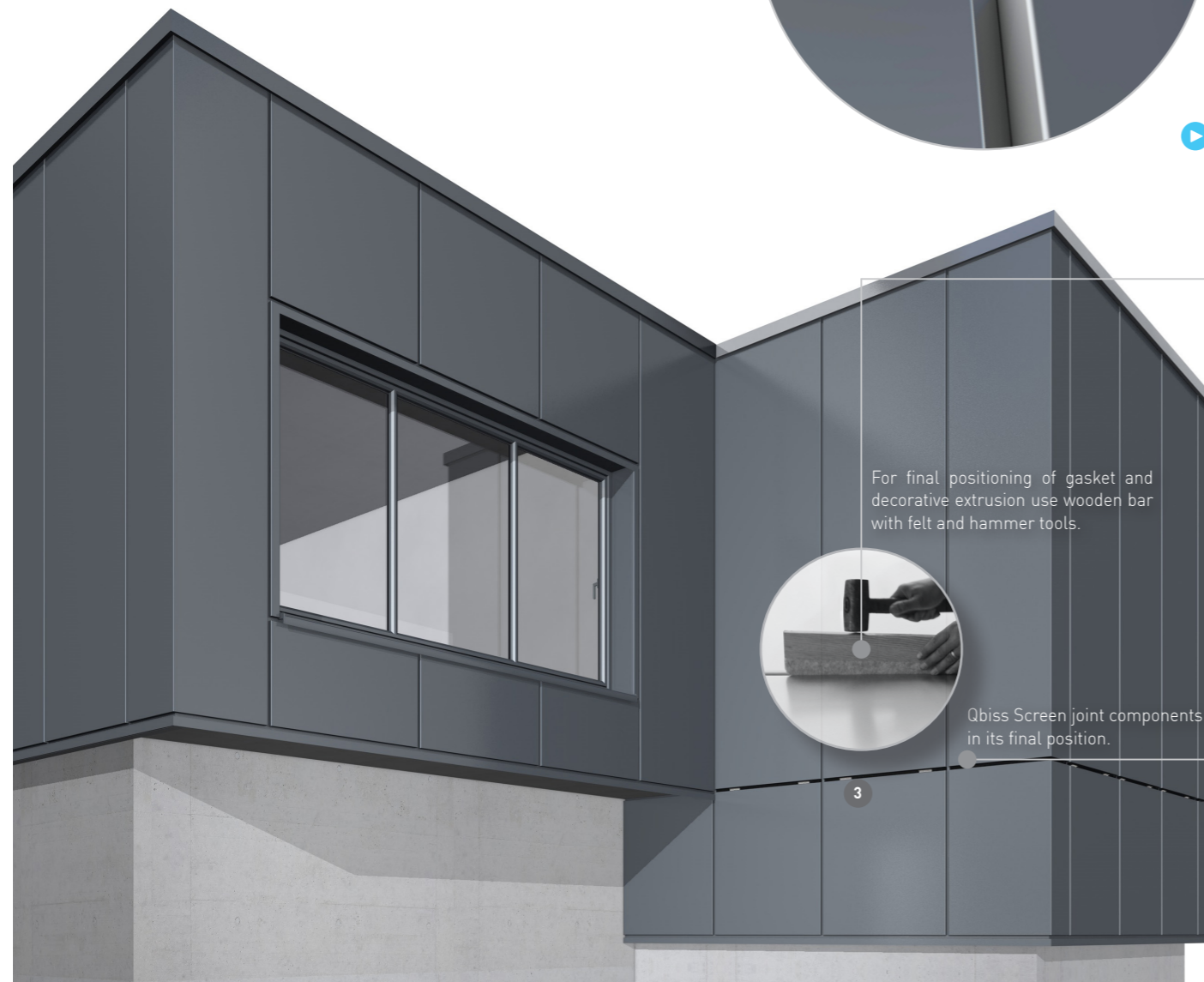
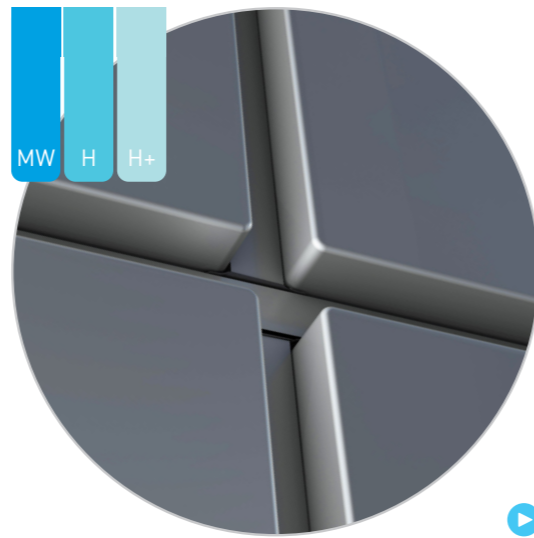

QBISS SCREEN FAÇADE ELEMENT JOINT DETAIL

1. Qbiss Screen façade element – already installed
2. Qbiss Screen façade element – installed last
3. Load bearing fixing plate
4. Electrochemical potential insulation tape
5. Qbiss Screen H, H+ installation cross spacer
6. Screws – wind load fixings
7. Screws – self-weight load fixings
8. PE-butyl tape
9. Transversal gasket together with decorative extrusion
10. Load bearing fixing element HF 63 (Qbiss Screen H+)

 [Link to system sealing chapter](#)



QBISS SCREEN H VERTICAL ELEMENT

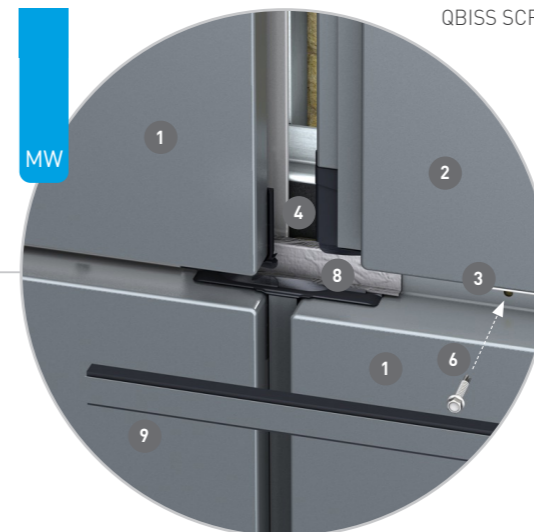

QBISS SCREEN MW JOINT

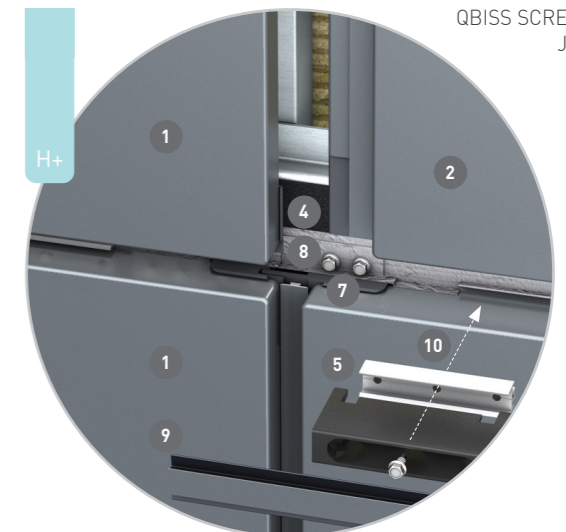

QBISS SCREEN H+ JOINT !

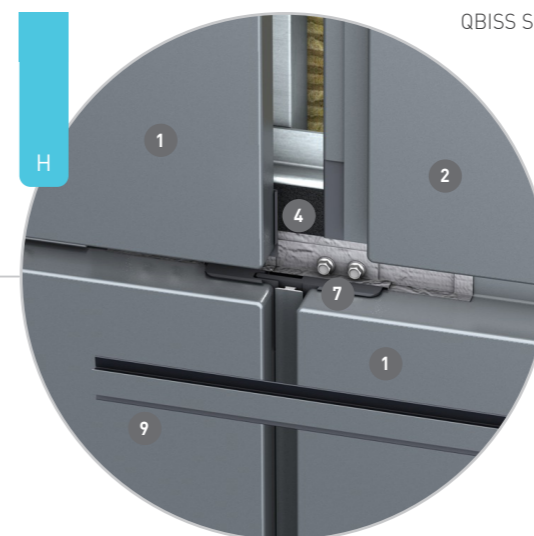

QBISS SCREEN H JOINT

- ! Qbiss Screen H+ vertical element is allowed to be used as an internal wall application only.
- Wooden bar with protective felt are used to insert the decorative extrusion and the transversal gasket into final position without damaging adjacent Qbiss Screen MW elements or decorative extrusion.

INSTALLATION STEP **5** PARAPET CAP AND OTHER DETAILS

NOTES / Installation of parapet cap is performed after all elements are mounted and transversal joints are aligned. The parapet finish is done using a parapet cap.

Parapet wall detail installation sequence:

1. Install an insect protection mesh to the load bearing profile using screws.
2. Attach the support for the parapet wall cap through the support for the lining onto the parapet wall substructure.
3. Place the parapet wall cap on the top / final Qbiss Screen horizontal façade element.
4. Attach the parapet wall cap with a screw to the lining support. 1 screw per meter is added in longitudinal joint to avoid deflection.

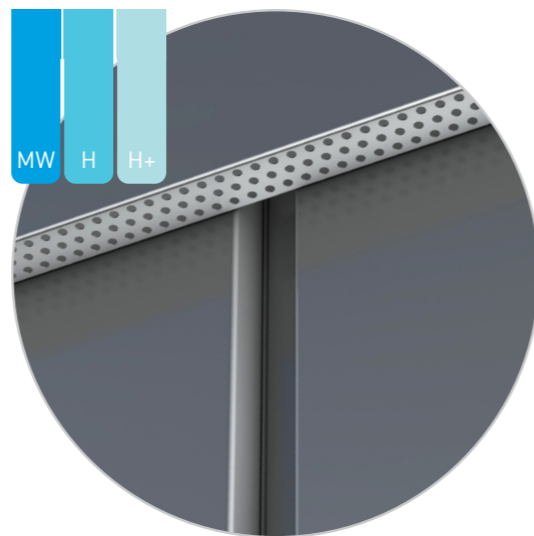
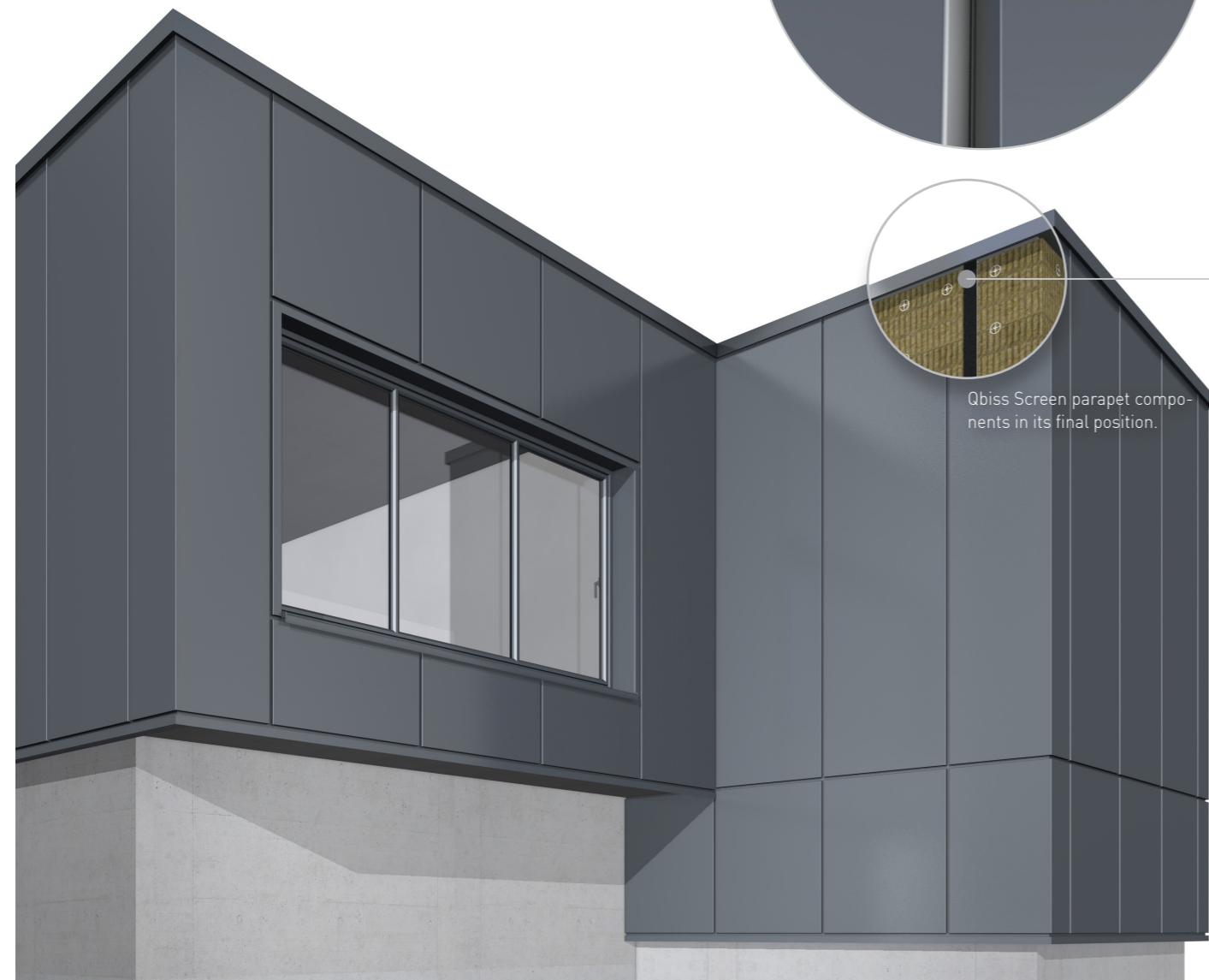

QBISS SCREEN ELEMENT INSTALLATION, PARAPET DETAIL

1. Qbiss Screen façade element
2. Decorative Al extrusion HF64 (recessed look of transversal joint)
3. Decorative Al extrusion HF40 (Qbiss Screen MW, H)
4. Transversal gasket
5. Screws – wind load fixing
6. Thermal insulation for ventilated façade
7. Load bearing profile
8. Load bearing fixing element HF 63 (Qbiss Screen H+)
9. Qbiss Screen parapet cap
10. Qbiss Screen outlet vents open

[🔗 Link to design details chapter](#)

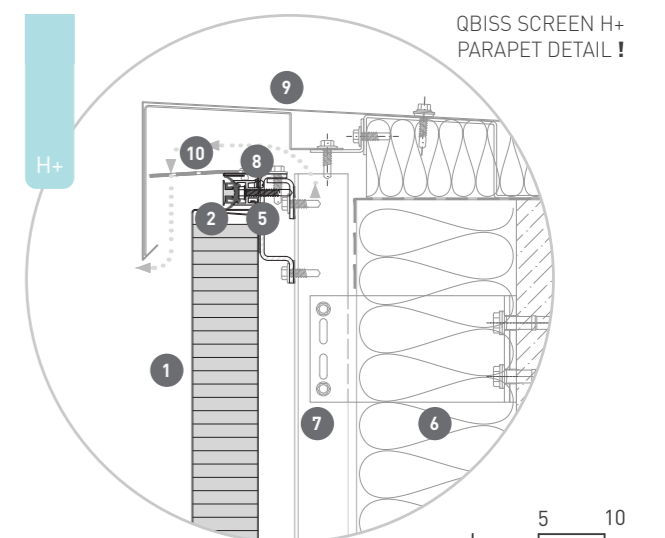
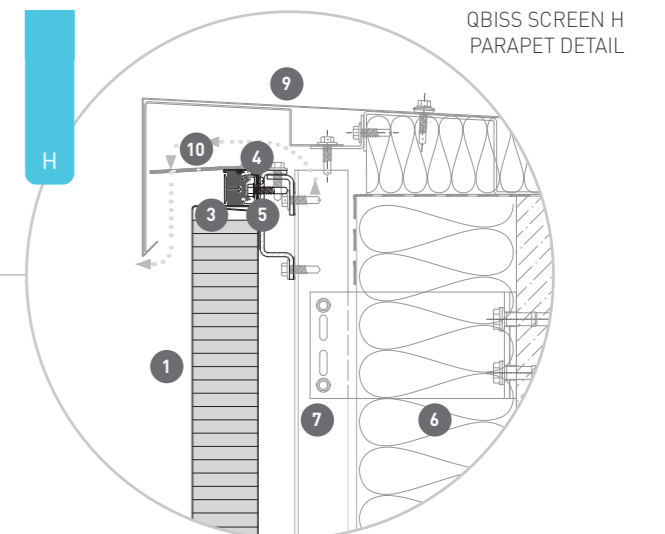
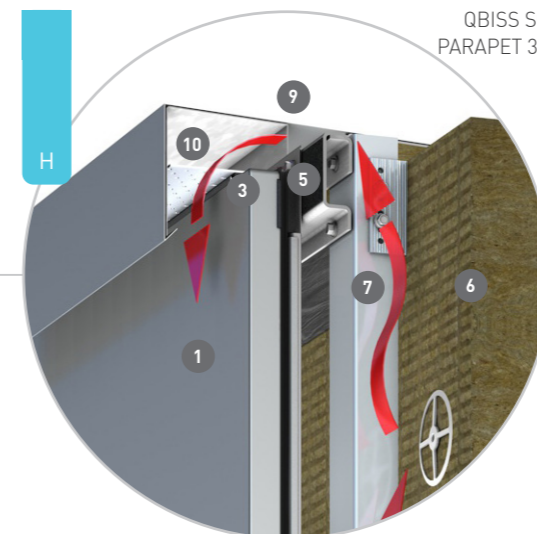
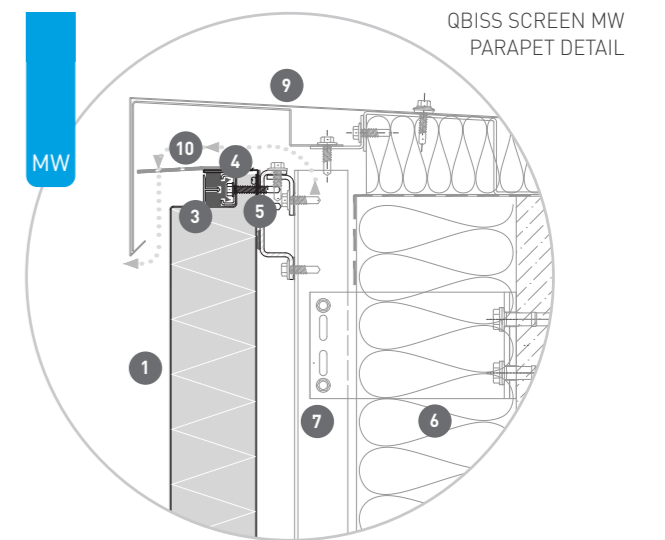



CHECK-LIST

STEPS FOR CHECKING THE INSTALLATION

Check the standard steps for evaluating whether the installation is performed according to installation guide and to ensure quality installation.

CHECK-LIST					
STEPS	STEP DESCRIPTION	CORRECT	INCORRECT	PAGE	NOTES
1	Substructure meets the tolerance requirements (horizontally, vertically, dimensions, plains).	✓			
2	Façade element substructure (vertical and horizontal) installed according to the details, dimensions and plains.				
3	Main structure attachment installed, attached and sealed according to the details.				
4	Electrochemical potential insulation tapes installed onto the substructure.				
5	Protective foil partially removed from the façade elements before the installation and fully removed after installation.				
6	First row of façade elements installed horizontally with vertical, horizontal joint gaps within tolerances.				
7	Façade elements attached through the internal metal skin according to the installation instructions.				
8	The number of screws used for attachment through the (fixing plate) external metal skin conforms to the design.				
9	Fixing screws should be tightneded acordingly (do not over-tight the screws).				
10	Gasket of the transversal joint and the decorative Al extrusion profile inserted into the horizontal, vertical joint with the wooden bar according to the details for extending and sealing at the beginning and end of gasket.				
11	Corner endings of façades installed, attached and sealed according to the details.				
12	Suitable tools used to cut façade elements.				
13	Window, door and other openings from aluminium profiles installed, attached and sealed according to the details.				
14	Linings installed, attached and sealed according to the details.				

HK15, KOLN
GERMANY

HORIZONTAL QBISS SCREEN MW

2018



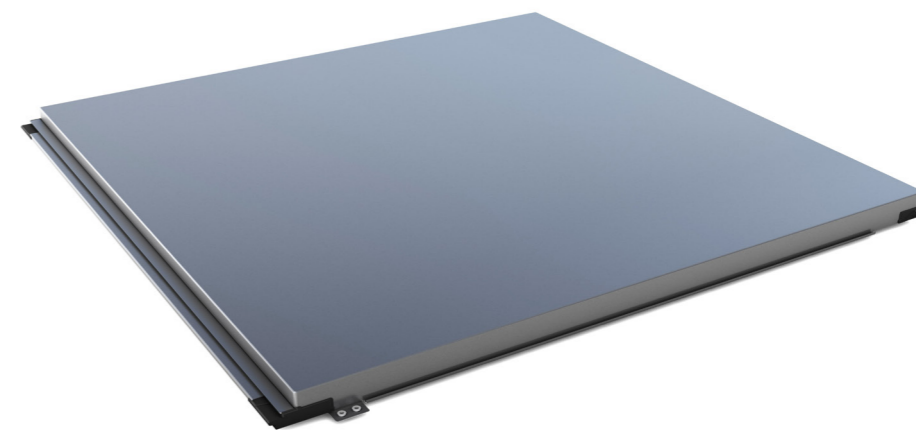

DAMAGED ELEMENTS

REPLACEMENT OF DAMAGED ELEMENTS

Damage or repair of the Qbiss Screen rainscreen, including all its range of modular elements, can be performed quickly and efficiently, without any compromise to façade's performance. It can also be appropriately replaced using different approaches depending of the nature of the damage and type of Qbiss Screen element.

REPLACEMENT OF HORIZONTAL QBISS SCREEN H+

Installation sequence A

1. With damaged Qbiss Screen element, remove the decorative extrusion HF 64 with transversal joint gasket from transversal joint.
2. Unscrew wind load screws and remove HF 63 fixing elements that holds the damaged Qbiss Screen element and adjacent element below the damaged one.



Installation sequence B

1. With adjacent Qbiss Screen element below the damaged one, remove the self-weight load screws. Be aware to hold this element against knocking back during the whole time of replacement process.
2. For the sake of safety, it is necessary to apply vacuum gripper to a damaged Qbiss Screen. The gripper must be attached to the crane. Remove the self-weight load screws from damaged Qbiss Screen element.
3. During extraction of damaged element and movement of its longitudinal joint it is still necessary to hold the adjacent Qbiss Screen element below. At one point the longitudinal joint of both elements are released. Damaged Qbiss Screen element now hangs on vacuum gripper only. The adjacent Qbiss Screen element can be temporary secured against knocking back.

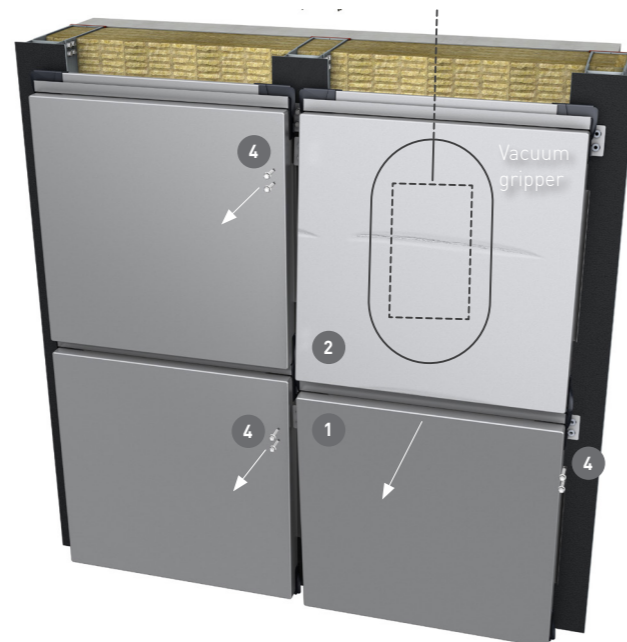

- ! The process of Qbiss Screen element replacement is also valid for Qbiss Screen H and MW elements, when damaged Qbiss Screen element is type 4.
- Prior execution, façade elements replacement procedures must be consulted and approved by Trimo's technical support team.

Installation sequence C

1. Align a newly replaced Qbiss Screen element to longitudinal joint of adjacent Qbiss Screen element below. Manipulation of a replacement element must be done using a vacuum gripper. In order to allow longitudinal joint of above Qbiss Screen to close correctly, the element below must be tilted out slightly.
2. Press both Qbiss Screen elements towards the façade sub-structure.



- 1 Adjacent Qbiss Screen façade element
- 2 Damaged Qbiss Screen façade element
- 3 Load bearing fixing element HF 63
- 4 Screws (self-weight load fixing)
- 5 Screws (wind load fixing)
- 6 Decorative extrusion HF 64 with transversal joint gasket
- 7 Replaced Qbiss Screen façade element

Installation sequence D

1. Insert an installation centering cross on bottom-left and bottom right corner of the replacement Qbiss Screen element as well as the adjacent element below. In this way we secure the correct positioning of both elements. Screw back all self-weight load fixing screws. Be aware to hold the Qbiss Screen element below against knocking back until all self-weight load fixing screws are tightened.
2. Screw HF 63 fixing elements that hold the Qbiss Screen elements with a wind load fixing screws. To allow correct positioning an installation cross spacer should be used. It is recommended not to fix in the same place as before the element has been replaced. Make an approx. 15 mm offset.
3. Insert the decorative extrusion HF 64 with transversal joint gaskets to transversal joints.

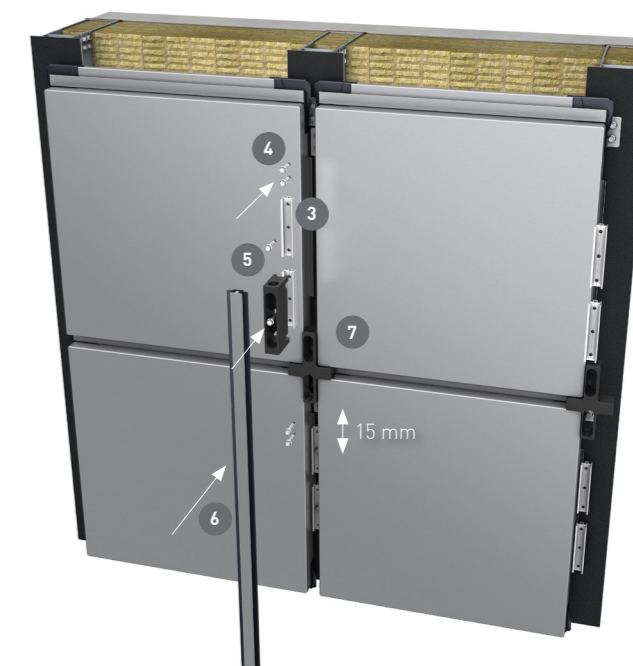

CUTTING AND SEALING

NOTES / The cutting area must be at a safe distance from the building, panel packages and from the install or unopened product. This will help to prevent metal shavings from blowing on into the finished metal surfaces. Metal shavings can travel up to 10 meters and so plan the location of your cutting station accordingly. The packages of panels should not be used as sawhorses, because the metal shavings may fall into the surface of panels and contaminate it and can cause future corrosion problems.

1. CUTTING THE ELEMENT

Sequence A

Draw cutting lines to the protective foil. Do not mark the surface with sharp objects that would damage the protective colour layer.

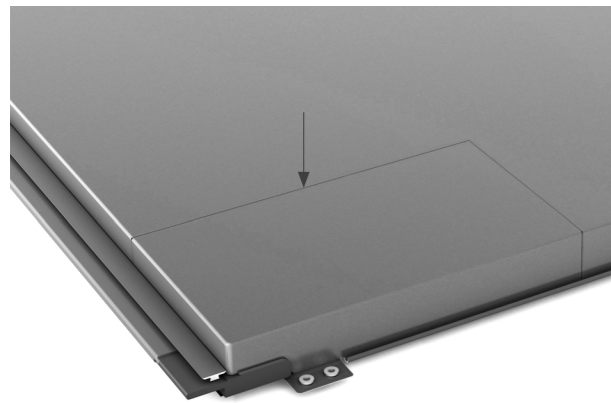

Sequence B

Before cutting, the Qbiss Screen element must be protected to avoid damaging the surface with a saw. Cut with a circular saw.

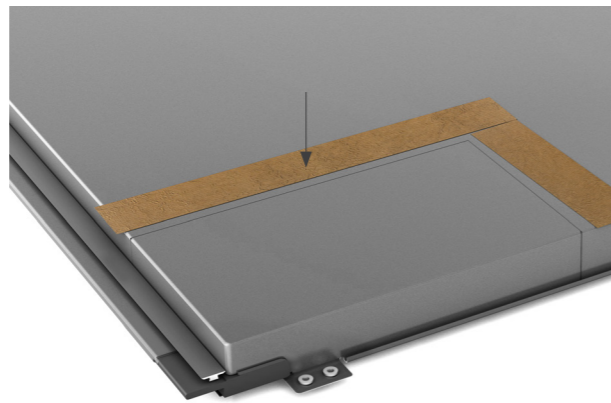

Sequence C

For smaller cut-outs where you can not cut with a circular saw use metal electroportable shears. Cut the steel skin on both sides of the element and remove steel-cut and honeycomb.

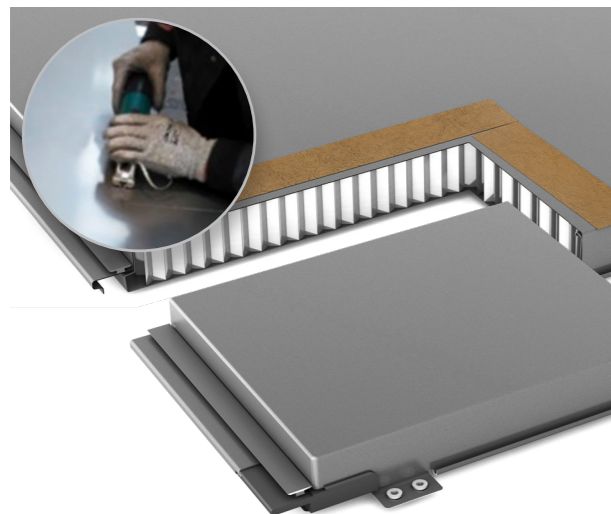

Sequence D

Gently sweep or blow off the surface of the sawdust. It is important to remove any of the shavings from the surface and from the inside of panel after cutting to reduce the risk of future corrosion. Do not use any metal objects to avoid damaging the surface.

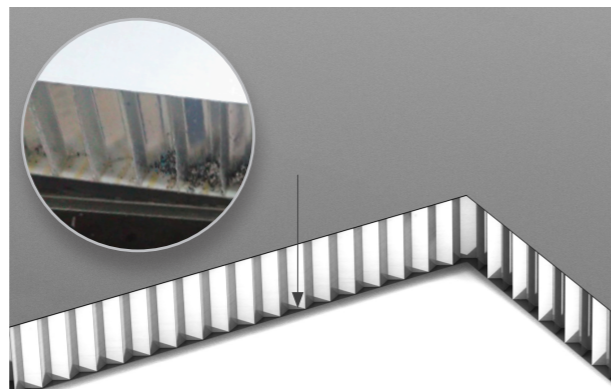

2. SEALING THE ELEMENT

Sequence A

Remove the protective foil. The surface must be hard, clean, dust and fat free. Remove all separated and badly attached pieces. Apply the sealing foil to the cut. To prevent moisture and water from entering the element, the foil should overlap at the corners as shown in the figure.

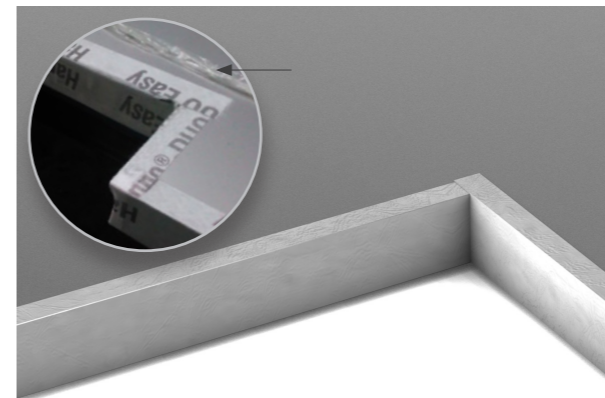

Sequence B

Close the cut-out with flashings.

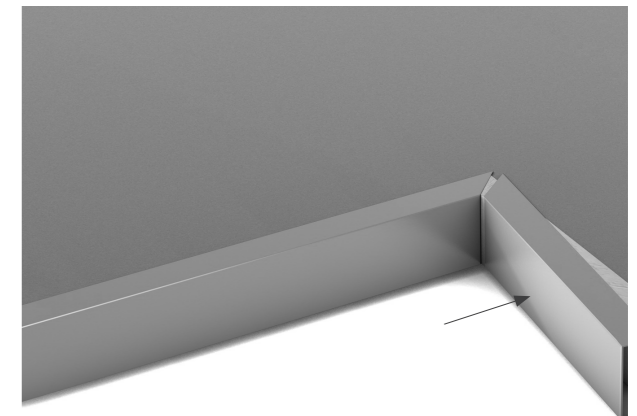

Sequence C

Rivet the flashings on the back-side of the element.

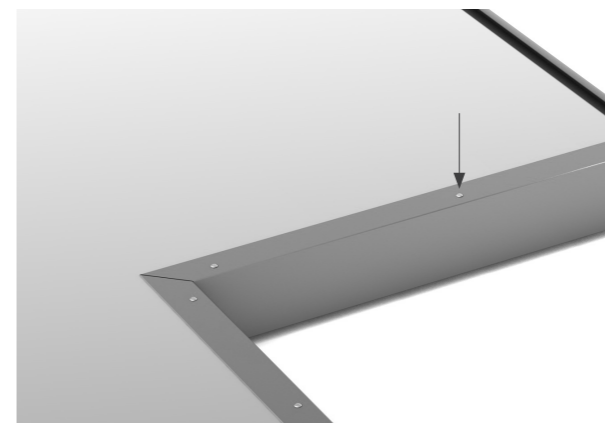

Sequence D

Apply the sealing adhesive kit on both, front and back side of the element, between the edge of flashing and steel skin of the element. Apply the sealing adhesive kit to the corners of the flashing.

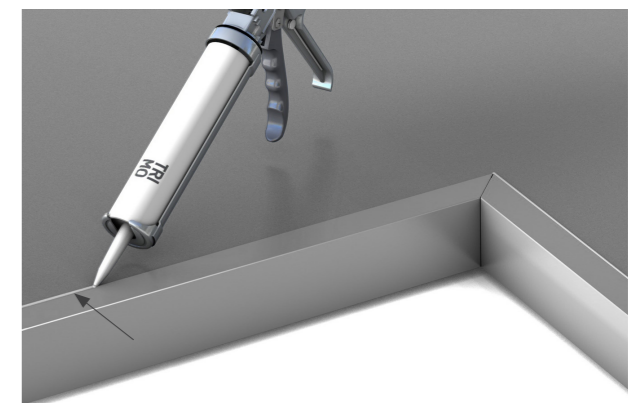

! If Qbiss Screen is cut or otherwise altered after delivery, Trimo can no longer guarantee panels integrity and loadbearing capacity.

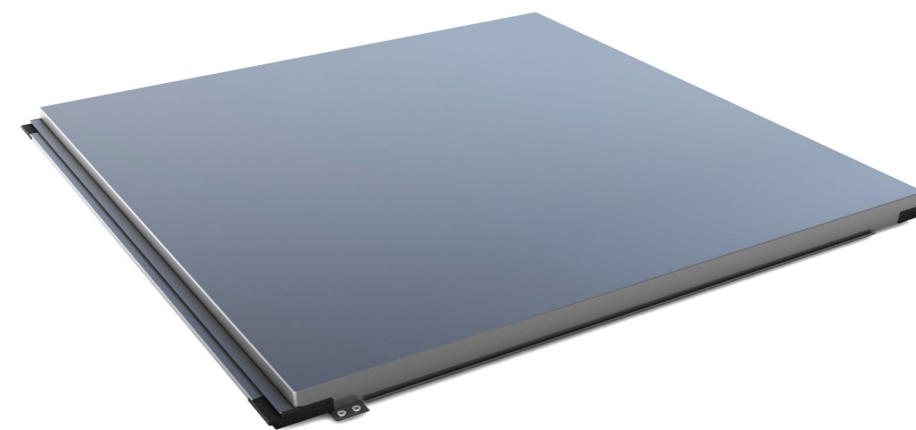

PRODUCT MANAGEMENT

MANAGING THE PRODUCTS

Trimo product management is the practice of strategically driving the development, market launch, and continual support and improvement of a company's façade products. We make sure that products stay in line with all decisions with regard to marketing and reflect the product's strategy. All Qbiss Screen family group products are constantly under supervision of highly dedicated engineers and thoroughly explained in technical product books available online. In that way Trimo is able to continuously develop and always offer new and high end façade products for its customers.

PRODUCT DEVELOPMENT

Trimo's development activities are based on the successful creation of innovative ideas and dedicated work resulting in high-quality products and solutions that meet the needs of all Trimo's clients. The added value of products and solutions is an important factor in the development of Trimo and its customers. Sustainable development and construction are the guiding principles of Trimo's development strategy for Trimo Group.

The company's latest developments focus on the areas related to reducing energy consumption in buildings and reducing the CO₂ footprint, improving energy balance and making buildings sustainable and more pleasant places to live and work.

Product development always considers criteria for calculating the impact of the entire life cycle of the product or solution (LCA - Life Cycle Assessment). In addition to new products, Trimo has successfully developed and accomplished individualised, project-based solutions for its customers.

Ideas are the lifeblood of any product and they can come from many places. Tools today allow product teams to crowd-source ideas directly from multiple stakeholders, including customers, sales, and suppliers.



Through innovative, flexible and energy-efficient solutions, Trimo's quality and customer support continues to impress as new markets and new opportunities are explored.

ASSOCIATED DOCUMENTS

QBISS SCREEN DOCUMENTS

Qbiss Screen book contains all the necessary information about the product. On top of this document, Qbiss Screen is supported with Qbiss Screen technical instruction for use, Packaging, transport and storage guide, Product portfolio brochure, Treatment of waste guide, BIM library instructions, Architectural details and Design details, which can all be attained from below.

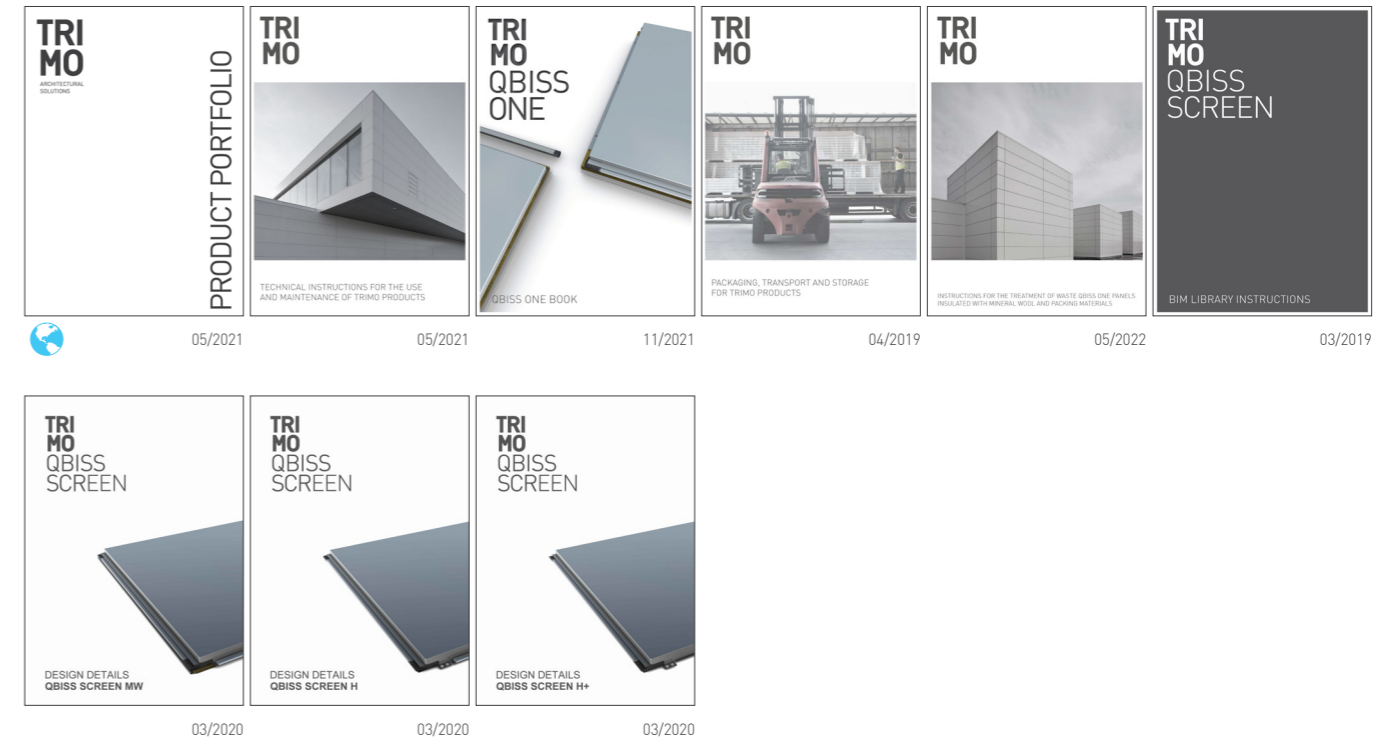

! For more detailed information also get acquainted with the technical description material on: www.trimo-group.com.

HEADQUARTERS

TRIMO D.O.O.

PRIJATELJEVA CESTA 12,

8210 TREBNJE, SLOVENIA

T: +386 (0)7 34 60 200

F: +386 (0)7 34 60 127

TRIMO@TRIMO-GROUP.COM

WWW.TRIMO-GROUP.COM

GLOBAL PRESENCE

Find your local contact

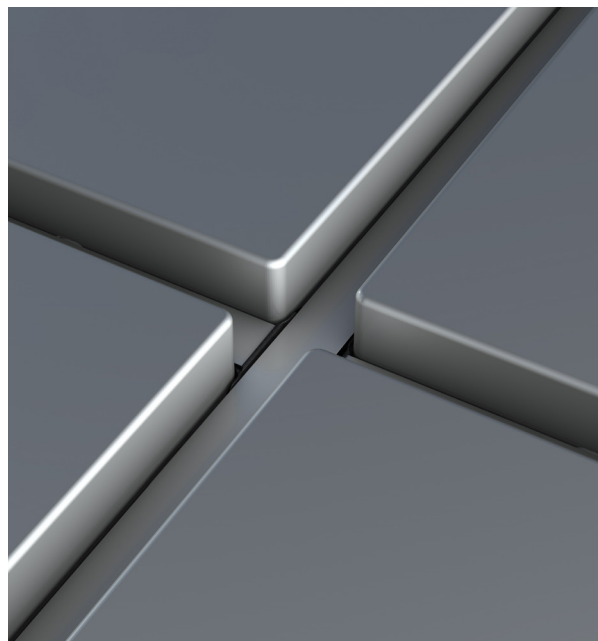

Trimo Group holds full copyrights on the information and details provided in this document, therefore any unauthorised reproduction and distribution is strictly prohibited. Professional Care has been taken to ensure that the information/details are accurate, correct, complete and not misleading. However, Trimo, including its subsidiaries, does not accept responsibility or liability for errors or information, which is found to be misleading. Information/details in this document are for general purposes only. It is the user's responsibility to check compliance with local laws. Any deviations in details and project solutions are the user's responsibility. Under no circumstances, will we be liable for any loss or damage including without limitation, indirect or consequential loss or damage, or any loss or damage whatsoever arising from lost profits as a result of or in connection with the use of this document. All information issued by Trimo Group is subject to continuous development and information/details contained in this document were current on the date of issue. It is the user's responsibility to obtain the most up-to-date information from Trimo when information/details are used for a project.

The latest version of the document is available at www.trimo-group.com. The latest version of the published document in English prevails over other translated documents.

For information about the delivery of panels see Trimo's General conditions (<https://trimo-group.com/en/trimo/general-conditions-of-sales>).